

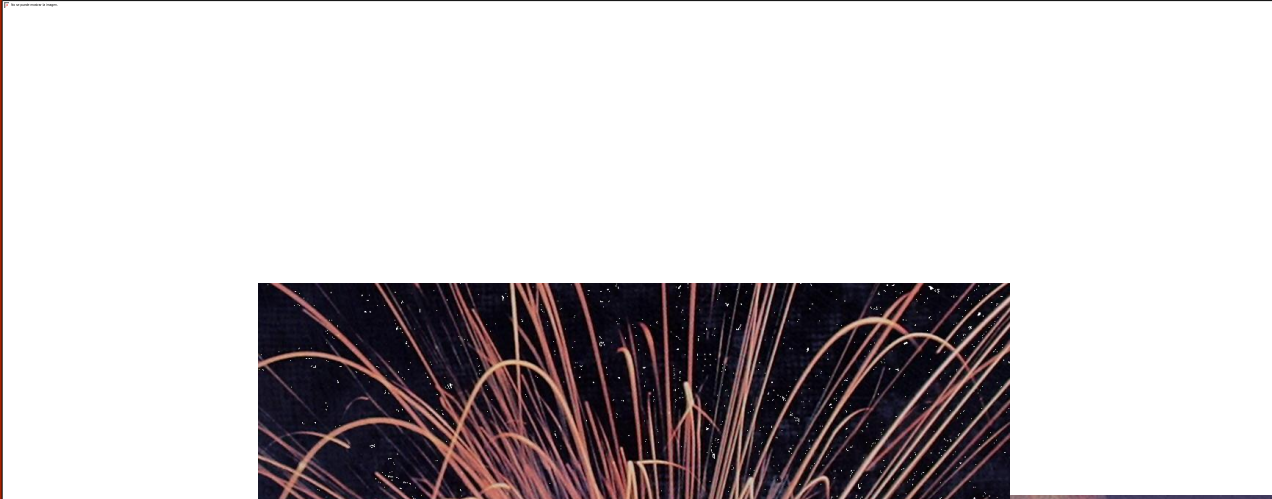

TECNOLOGIA







PRODUCTO
A
FABR



PROCESO
DE



SOLUCION
TECNICO-
ECONOMICA

mecan
máquin
pieza d
estruct
repara
planta

depende de
omo :
procura

al
erial
cución
componente
de sollicitación
de máquina

caridad a producir
aceptación del usuario

abulonado
SOLDADURA



Quando usar soldadura?

Quando se dice
que dos piezas
están soldadas?

• Unión de piezas
en forma FIJA

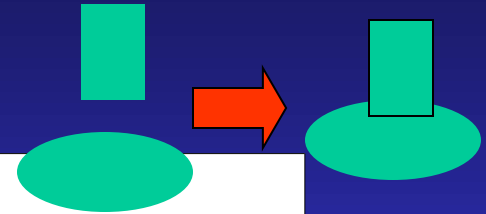

• Reparación de piezas fisuradas o rotas



• Piezas desgastadas

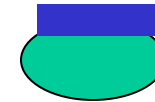

• Cuando son capaces de satisfacer los
requerimientos de diseño

• Cuando los esfuerzos de trabajo
pueden ser soportados tanto
por las piezas a unir como por
la unión en sí



Considerando el caso general de diseño, el cual es la UNION de piezas

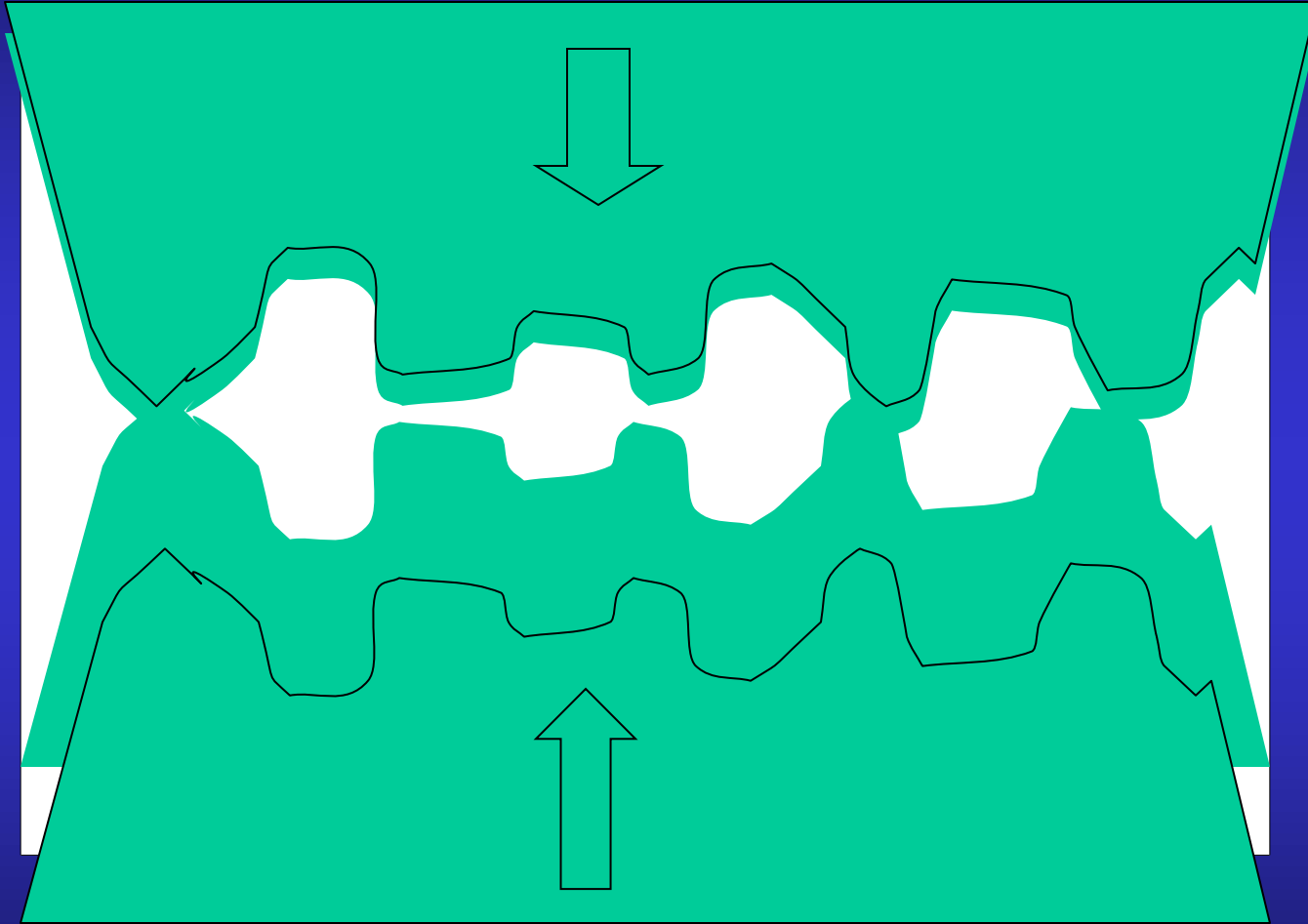

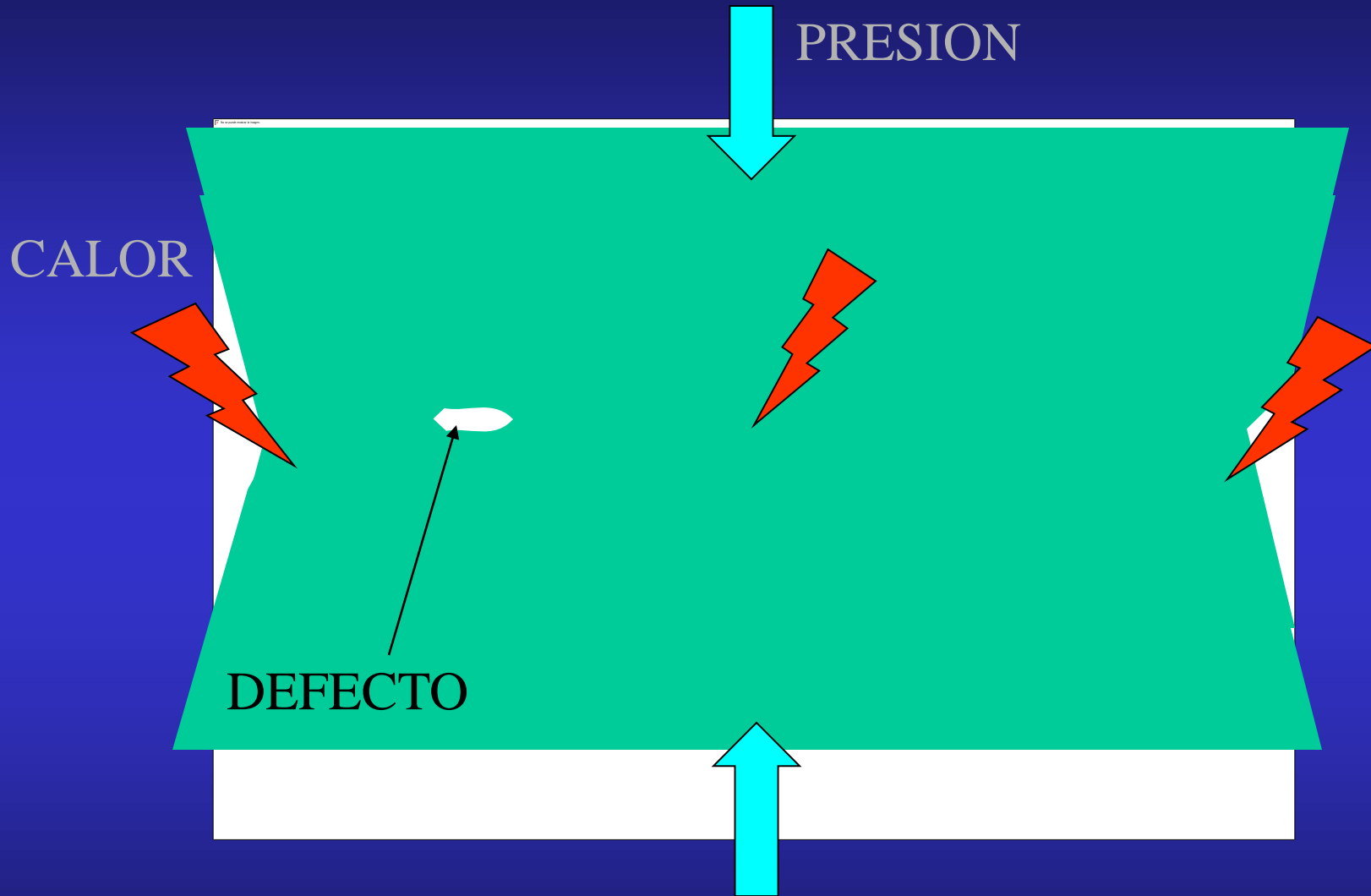



La aplicación de un proceso de soldadura implica la formación de una JUNTA SOLDADA, la cual debe satisfacer los requerimientos de sollicitación de la pieza o componente.

Esto está indicando que la JUNTA SOLDADA

DEBE SER SANA

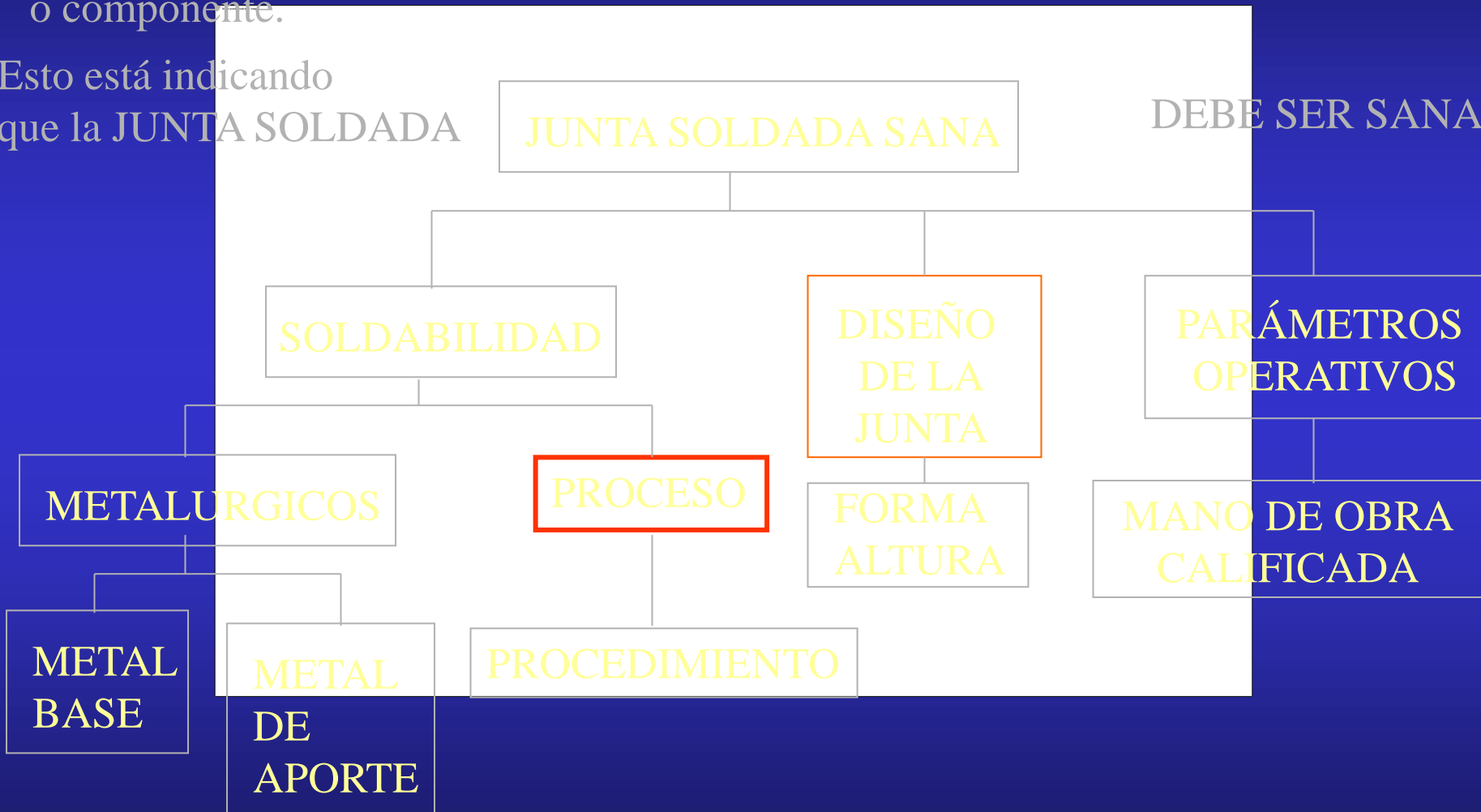

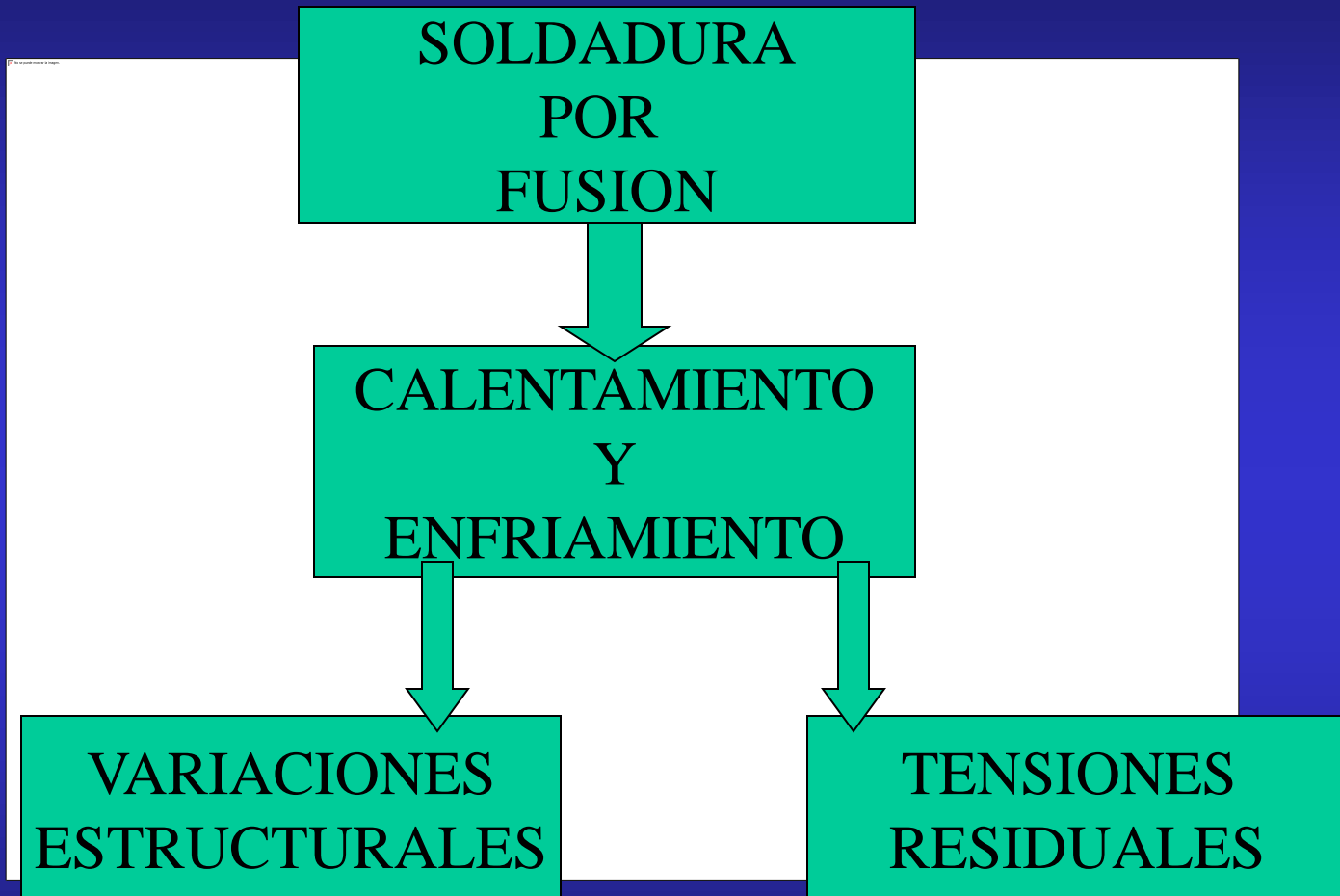

EFFECTOS DE LA SOLDADURA

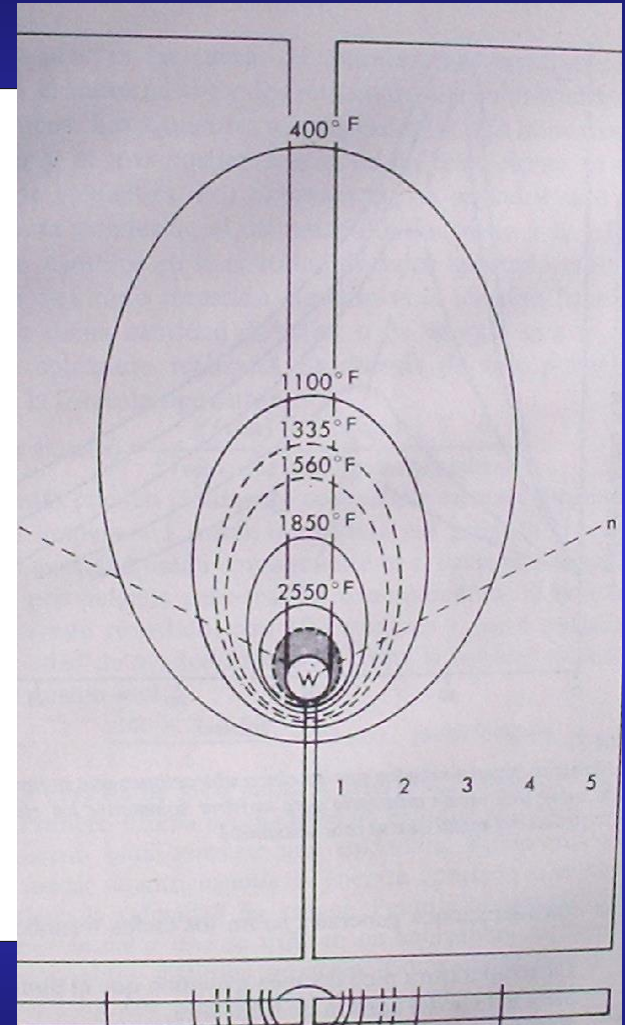
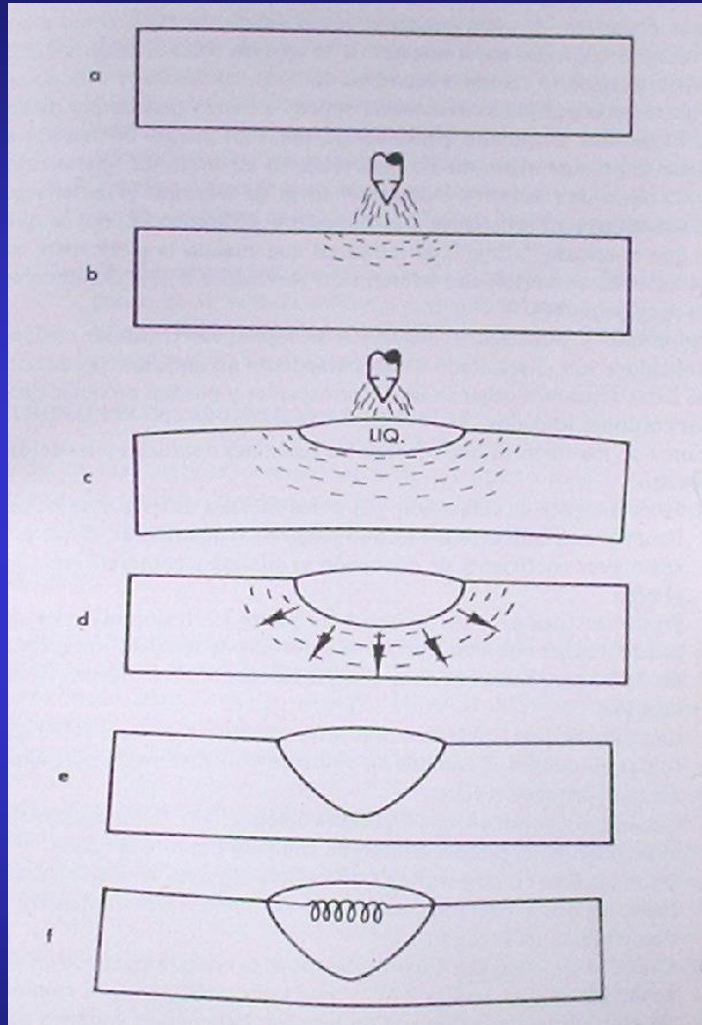

EFFECTOS DE LA SOLDADURA

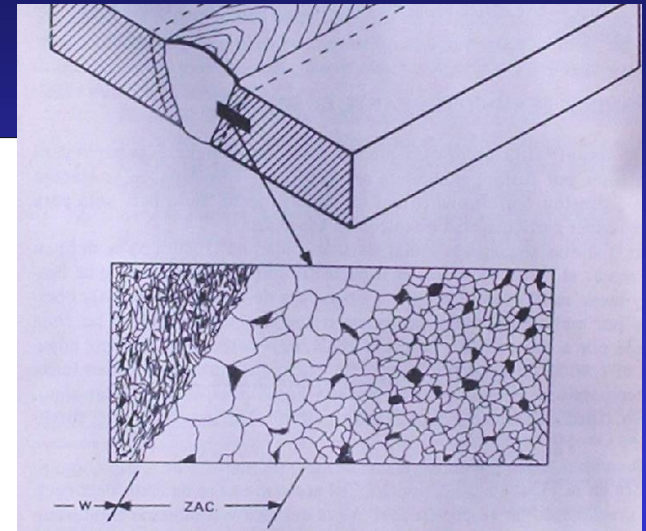
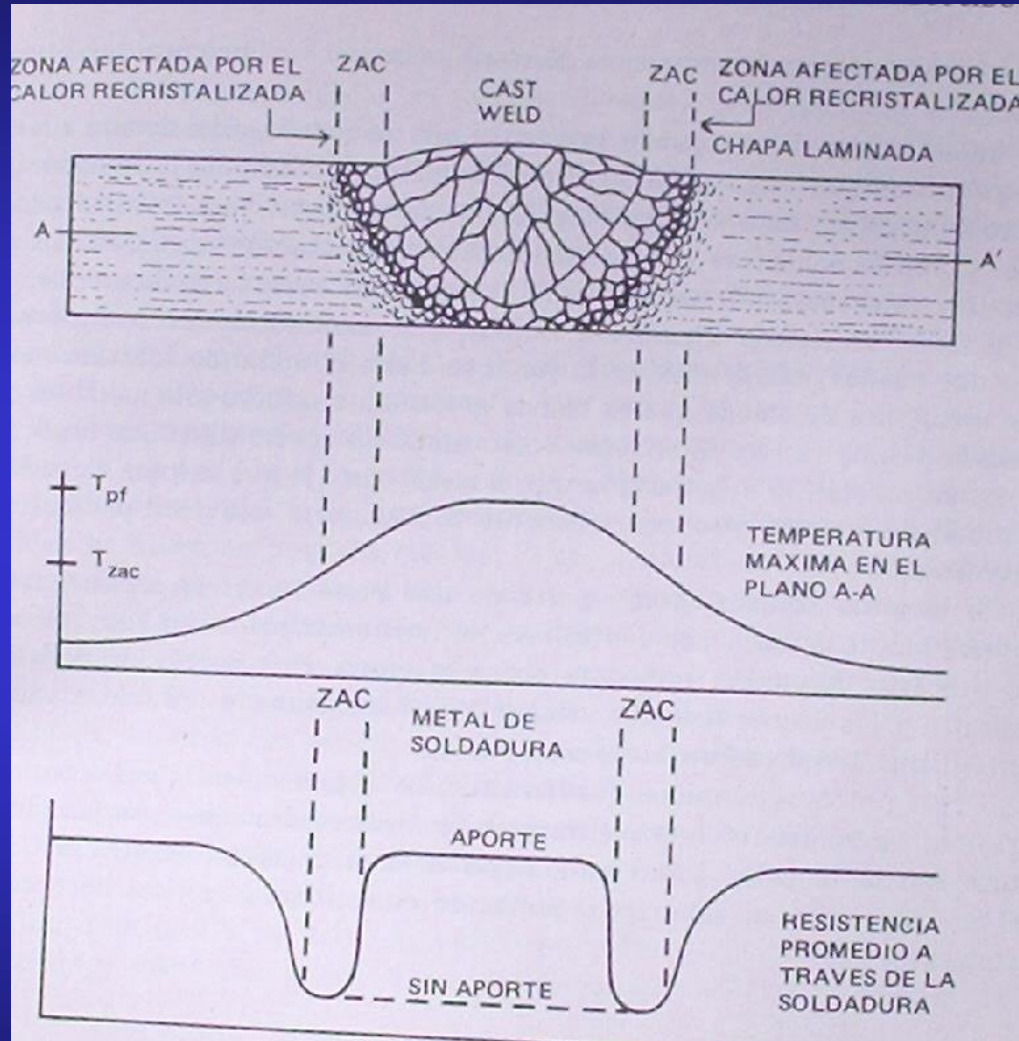

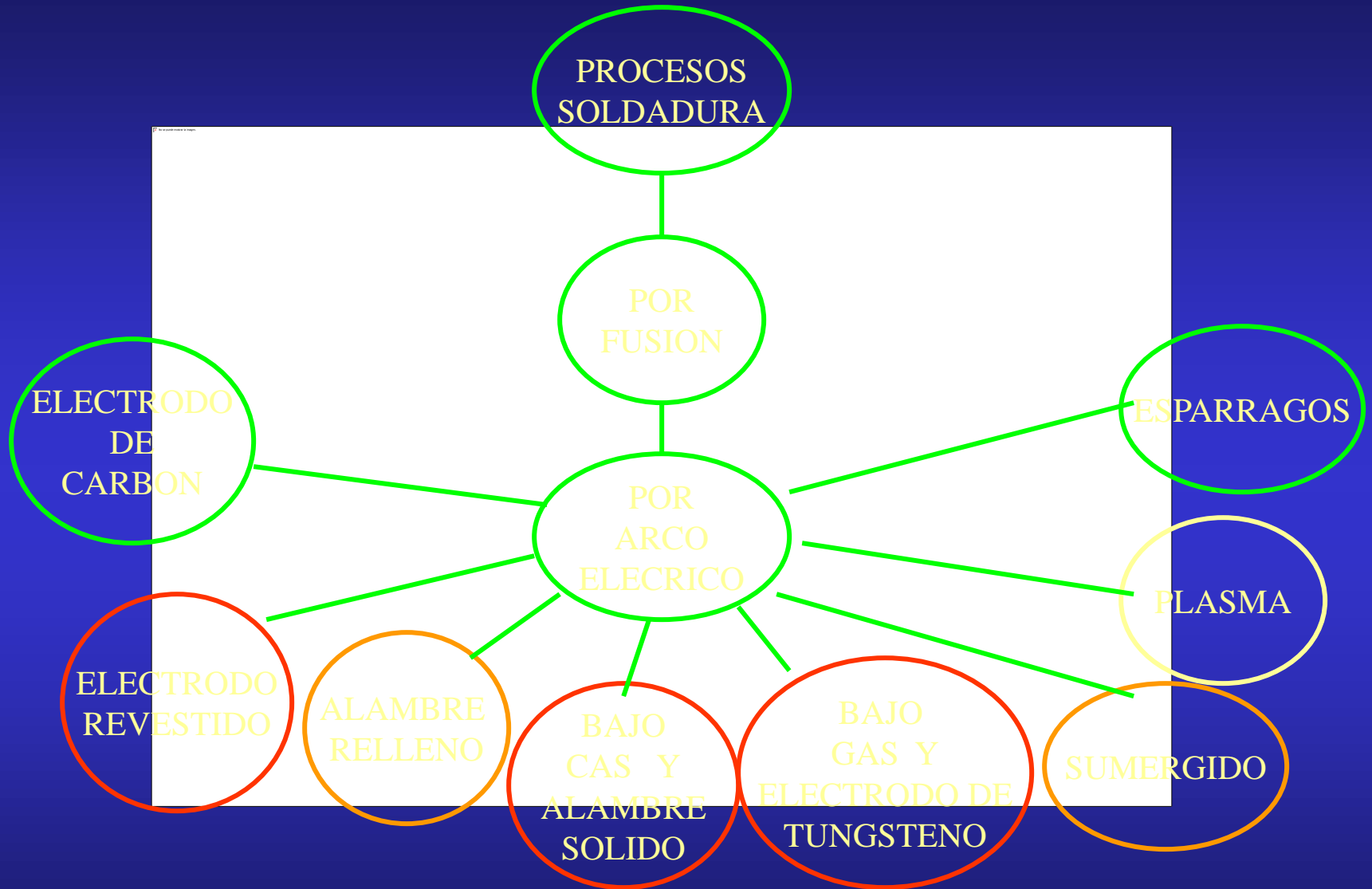

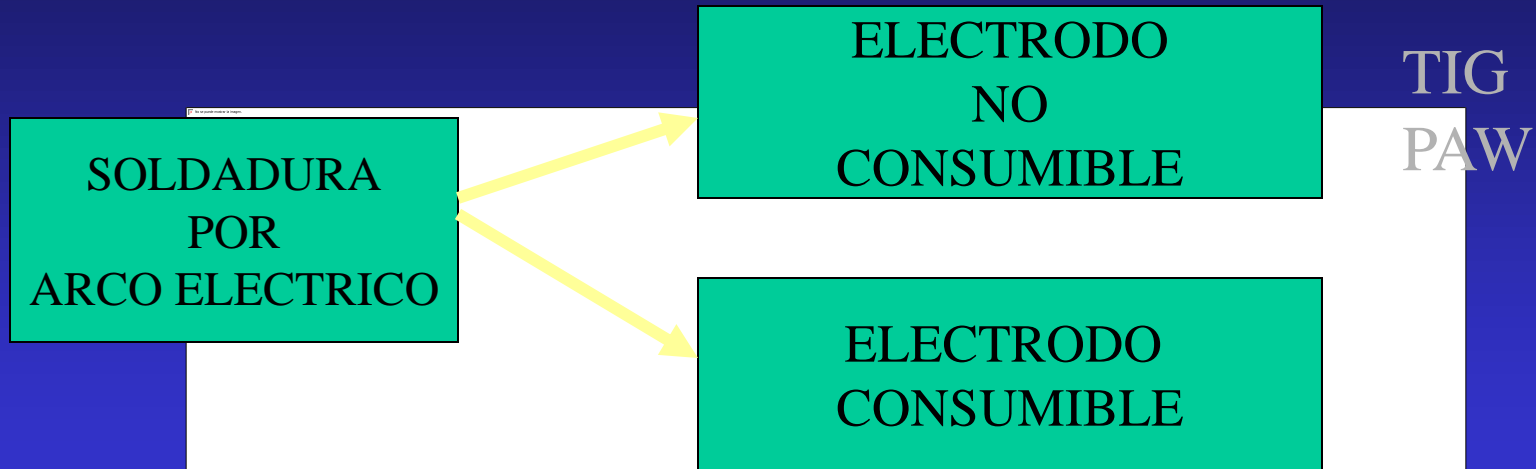

EN TODOS ELLOS LA ENERGIA PUESTA EN JUEGO SERÁ:





INDICE PARA EL DESARROLLO DE LAS SIGUIENTES CLASES

- * JUNTAS, SUS DISTINTOS TIPOS
- * CALCULO DE LA ALTURA DE CORDÓN
- * DISTINTOS PROCESOS DE SOLDADURA POR ARCO
- * CALIFICACIÓN DE SOLDADORES
- * ENSAYOS, DESTRUCTIVOS Y NO DESTRUCTIVOS
- * PROCESOS DE CORTE TÉRMICO
- * POSICIONADORES DE SOLDADURA
- * SOLDADURA ROBOTIZADA

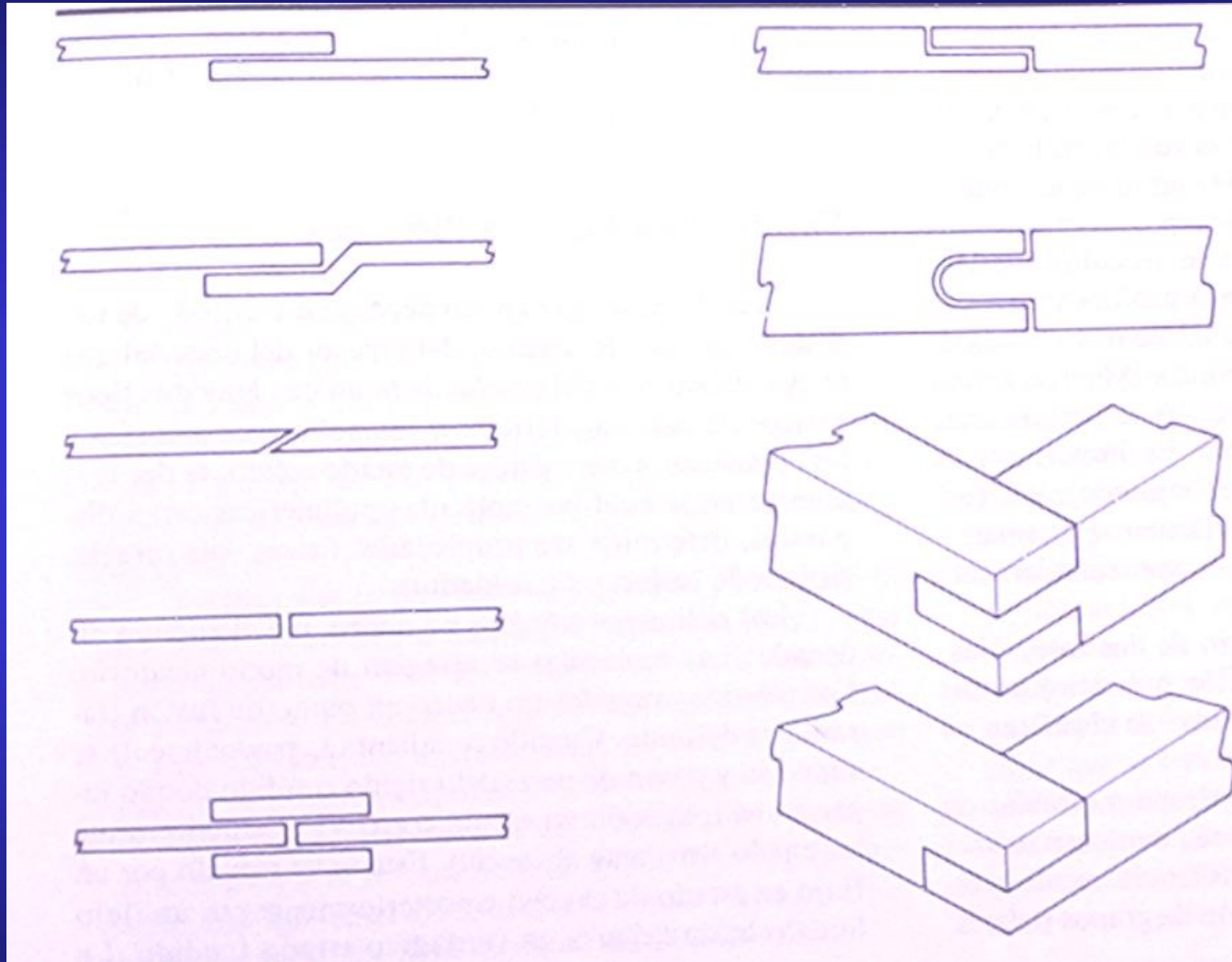

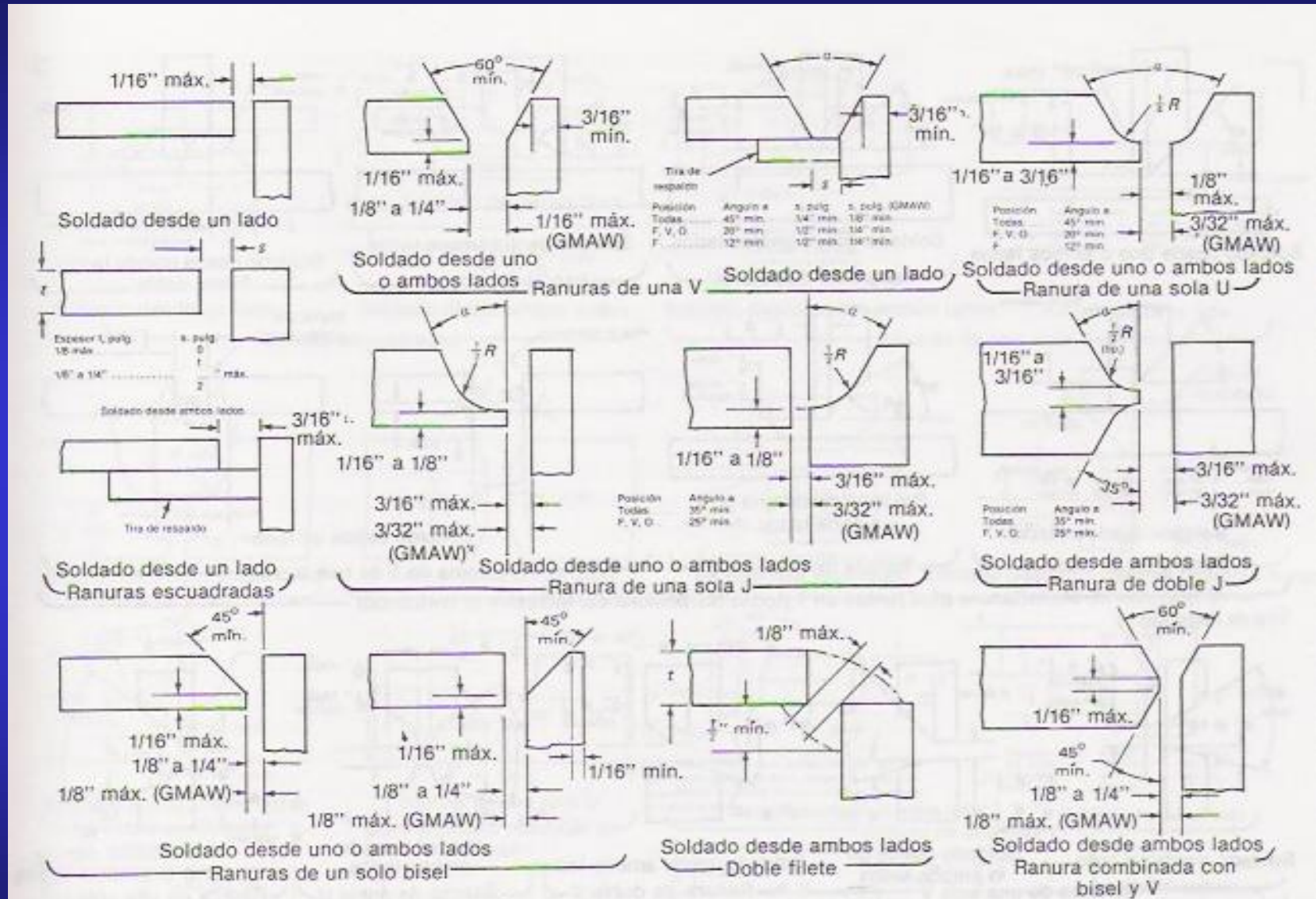

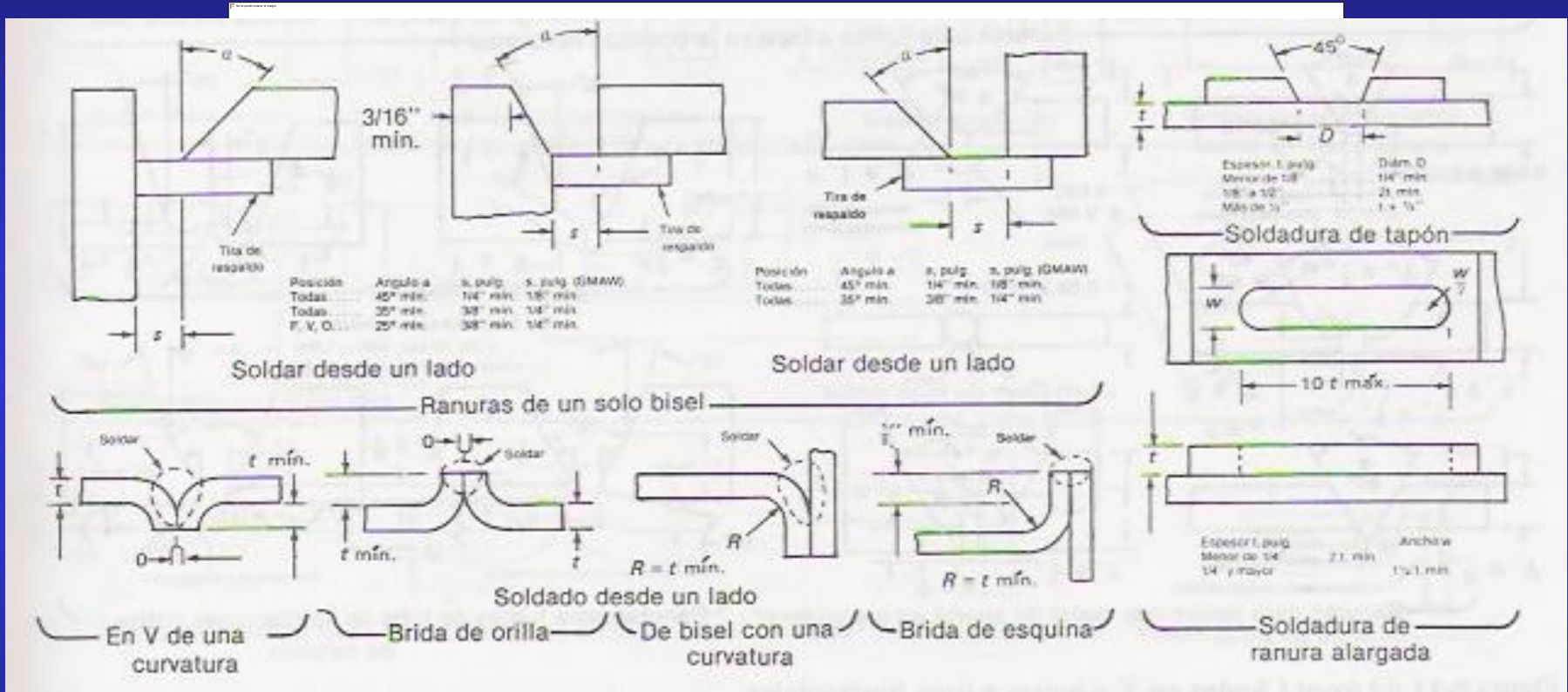

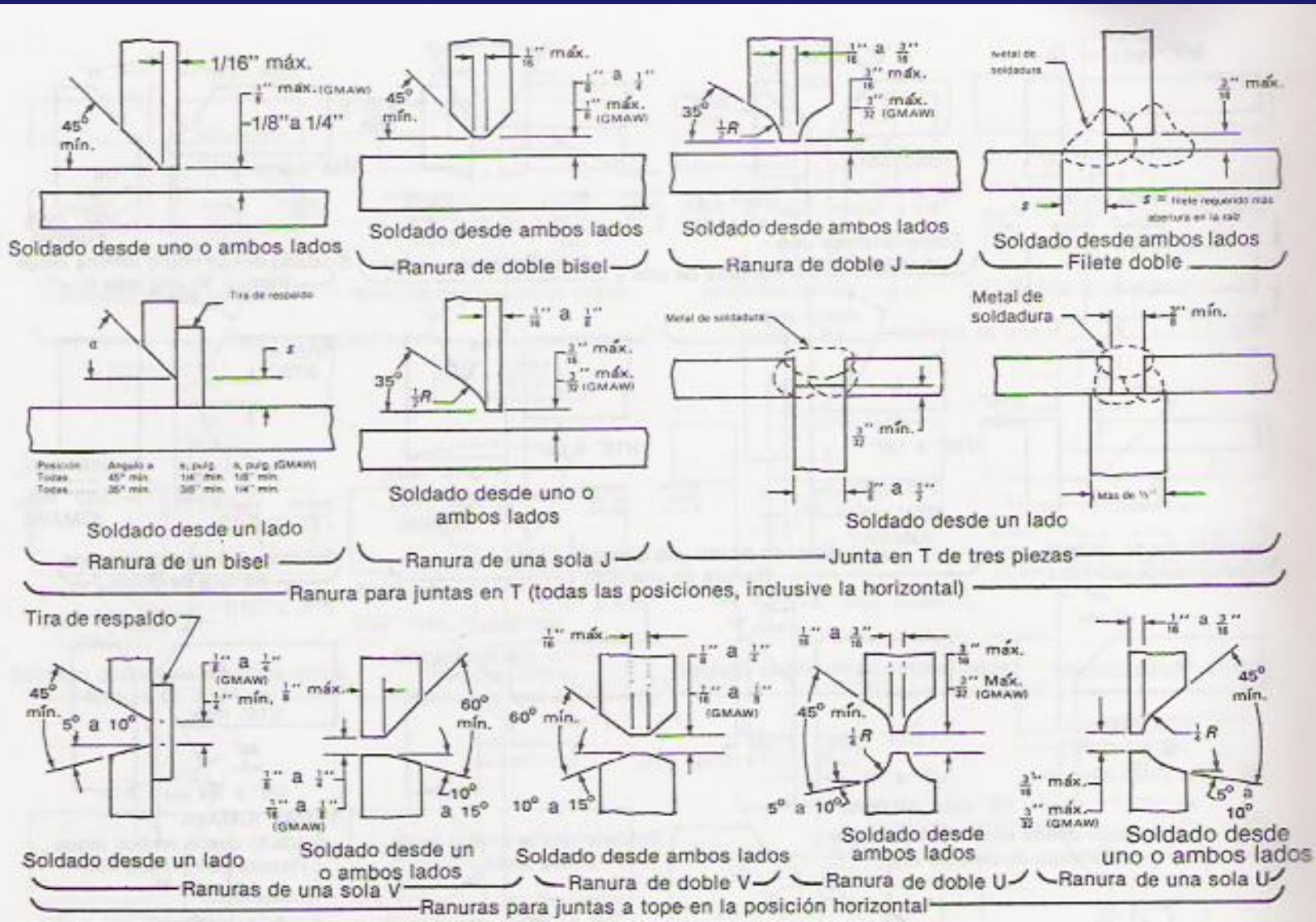

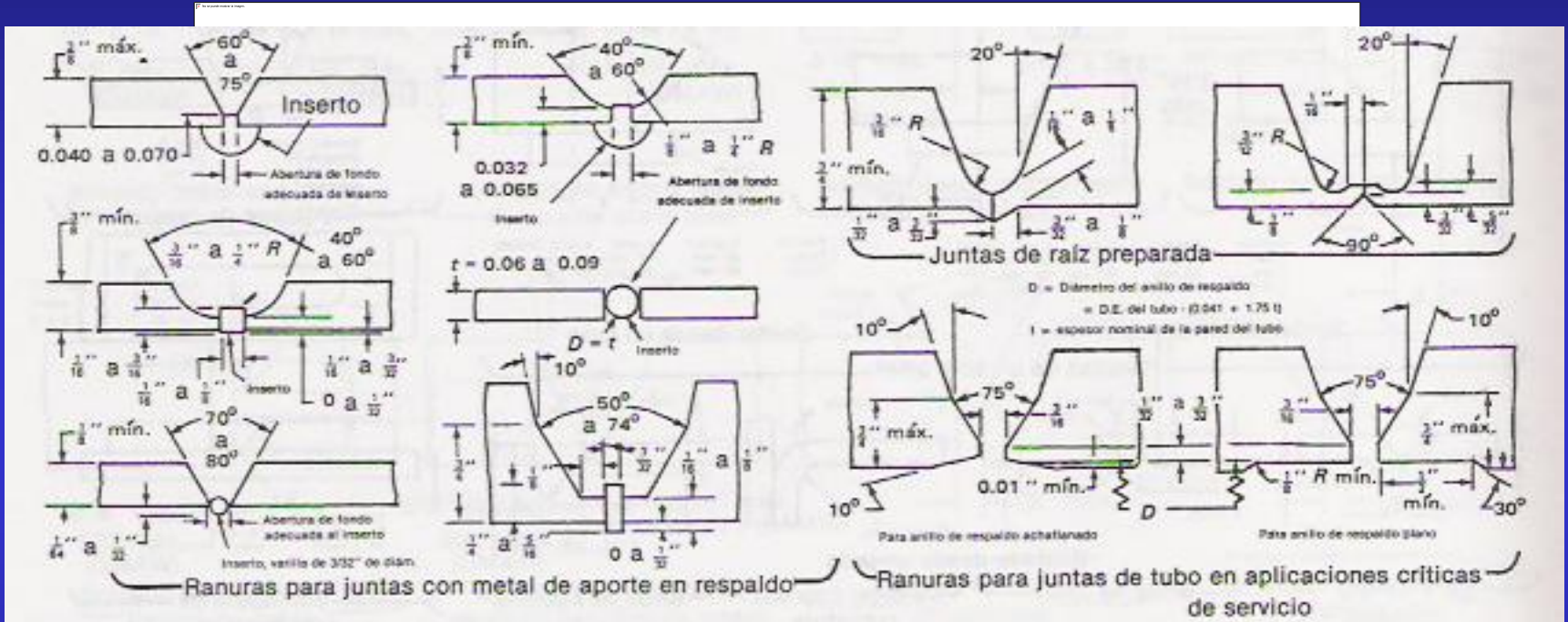

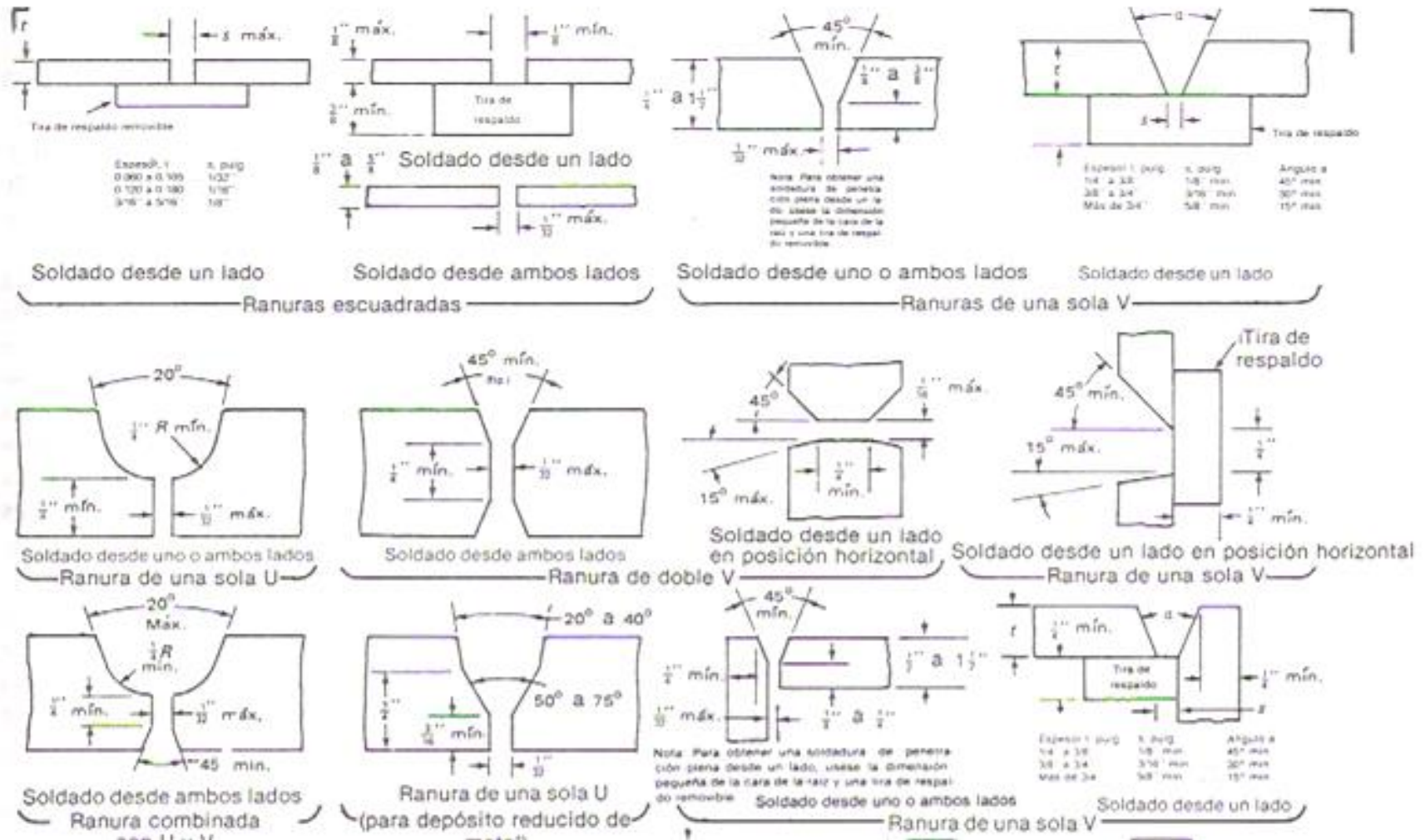

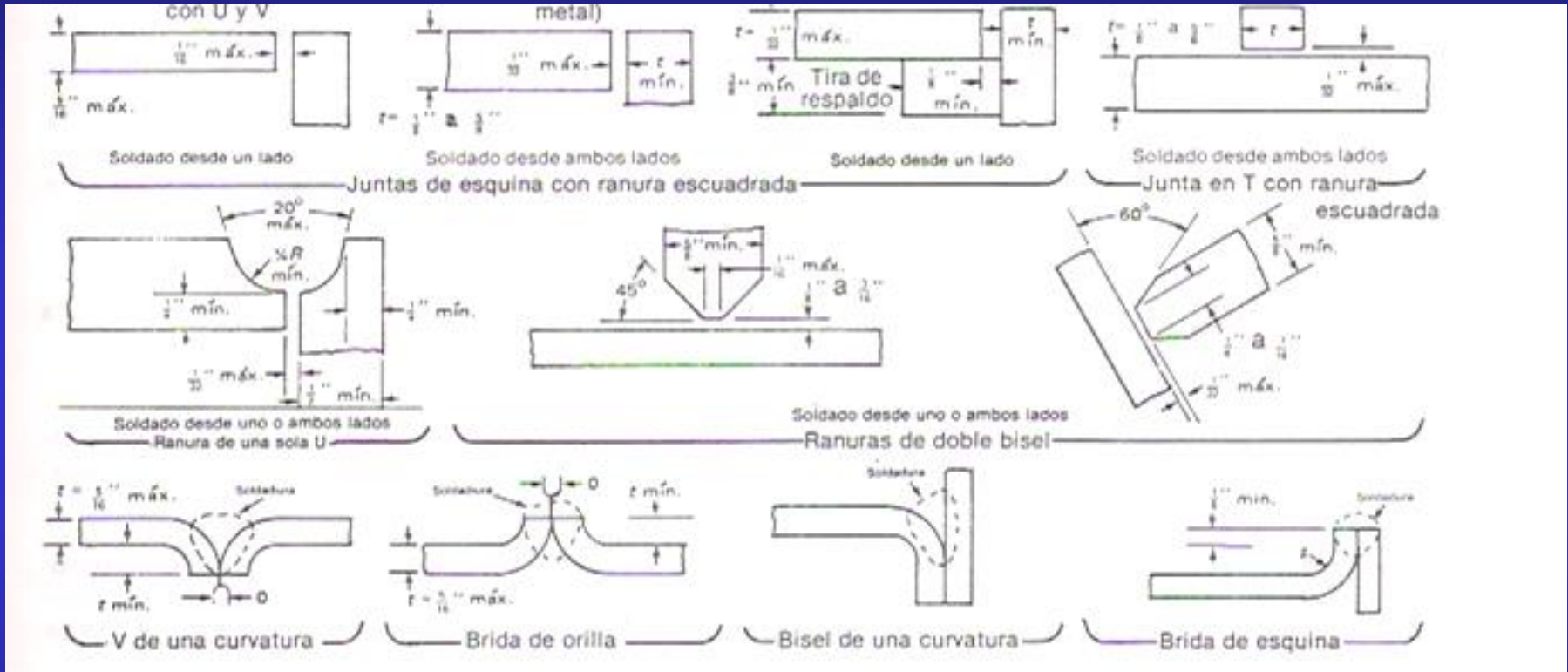



DISEÑO DE JUNTA	ESPESOR S mm	NUMERO DE PASADAS	DIAMETRO ELECTRODO TUNGSTENO mm	SEPARACION b mm	ANGULO BISEL α grados	TALON C mm
	0,2...2 1...3 1...3	1 2 1	1,6 1,6 3,2	0 0 0,1s	- - -	
	2...3 3...6 3...12	1 2 2	1,6...2,4 1,6...2,4 2,4...3,2	0...0,1s 0,1s 0,1s	30...60 30...60 30...90	0,1...0,25s 0,1...0,25s 0,1...0,25s
	6...12 6...20	2...4 2...6	2,4 3,2	0,1s 0,1s	30...90 30...90	0,1...0,25s 0,1...0,25s
	6...20	2...10	2,4...3,2	0,1s	15...30	0,1...0,25s
	20...37	8...20	3,2	0,1s	15...30	0,1...0,25s
	1...3 3...12	1 2...3	1,6 2,4	0,1s 0,1s	0...45 30...45	0,1...0,25s 0,1...0,25s

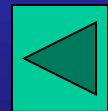
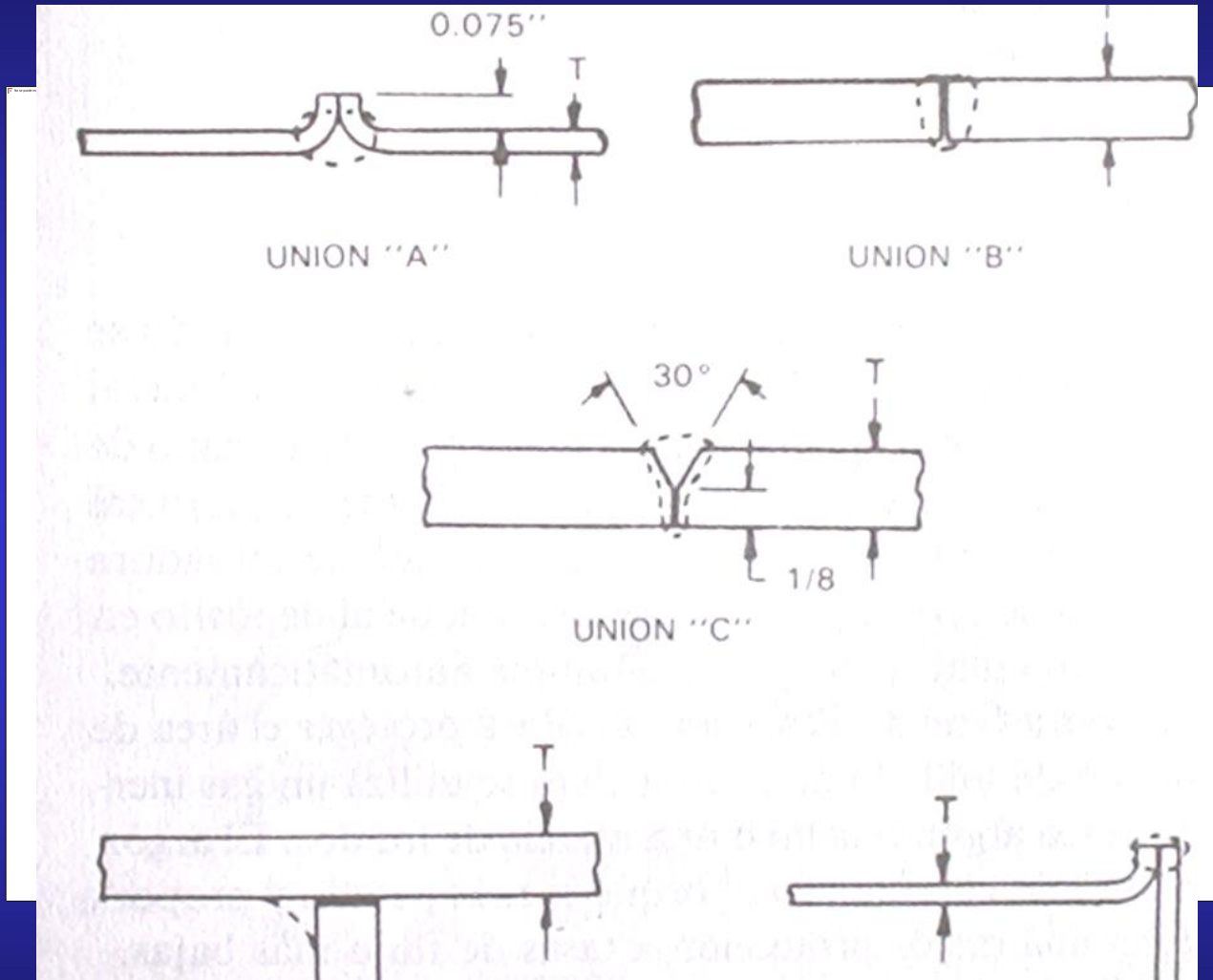

CALCULO DE ALTURA DE CORDÓN



Dimensiones de la soldadura

Flexión

Torsión

①

Soldado

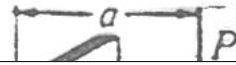

Soldado

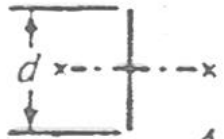
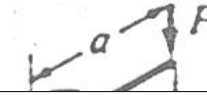

$$A_w =$$

$$= d^3/12$$

$$= P_a$$

$$= d/2$$

②

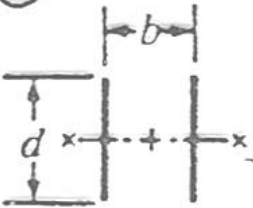

$$A_w =$$

P

$$= \frac{d(3b^2 + d^2)}{6}$$

③

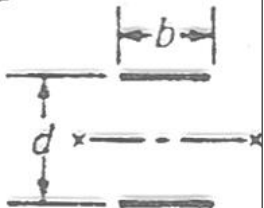

$$A_w = 2b$$

P

$$J_w = \frac{b^3 + 3bd^2}{6}$$

CALCULO DE ALTURA DE CORDÓN



④

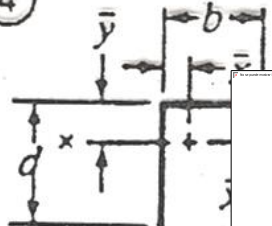

$$A_w = b + d$$



⑤

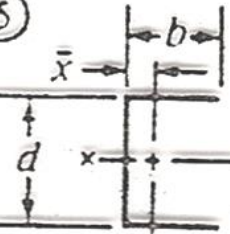

$$A_w = d + 2b \quad \bar{x}$$

⑥

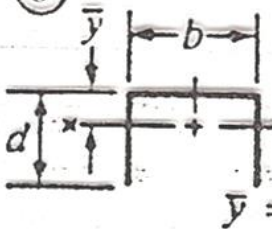

$$A_w = b + 2d$$

$$\frac{b + d)^4 - 6b^2d^2}{12(b + d)}$$

$$\frac{b^2(b + d)^2}{(2b + d)}$$

Parte sup.: $Z_w = \frac{d^2(2b + d)}{3(b + d)}$ $J_w = \frac{(b + 2d)^3}{12} - \frac{d^2(b + d)^2}{(b + 2d)}$

CALCULO DE ALTURA DE CORDÓN

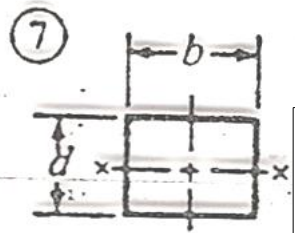

$$A_w = 2b + 2d$$

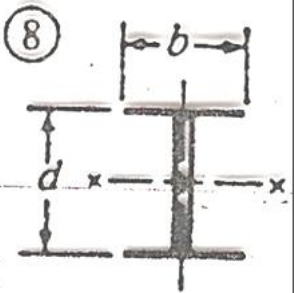

$$A_w = 2b + 2d$$

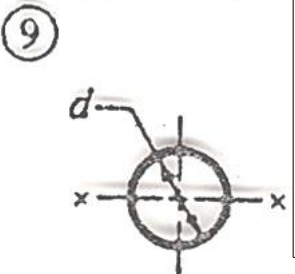

$$A_w = \pi d$$

Soldar todo
alrededor

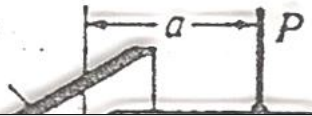

Soldar todo
alrededor

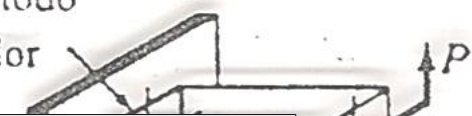

$$J_w = \frac{(b+d)^3}{6}$$

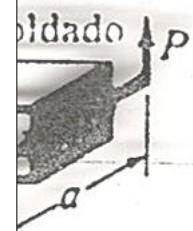

$$\frac{b^3 + 3bd^2 + d^3}{6}$$

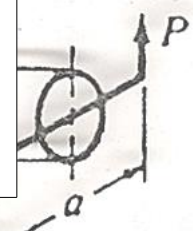

$$J_w = \pi(d^3/4)$$

$$Z_w = \pi(d^2/4)$$



TIPO DE ESFUERZO

FORMULA PARA FUERZA



J_w

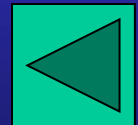

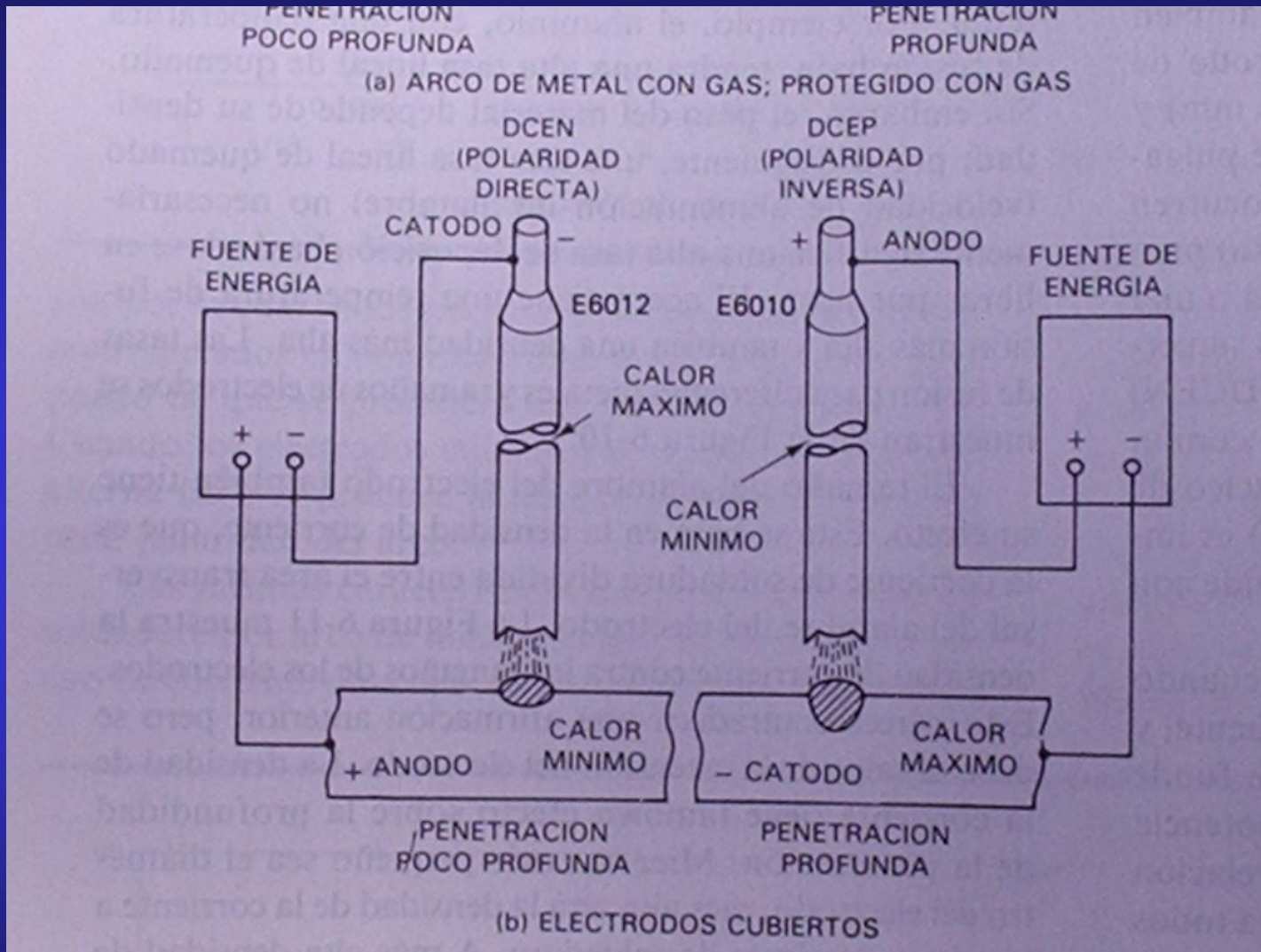



EQUIPAMIENTO DEL PROCESO



ELECTRODO
PINZA
FUENTE





EQUIPAMIENTO DEL PROCESO

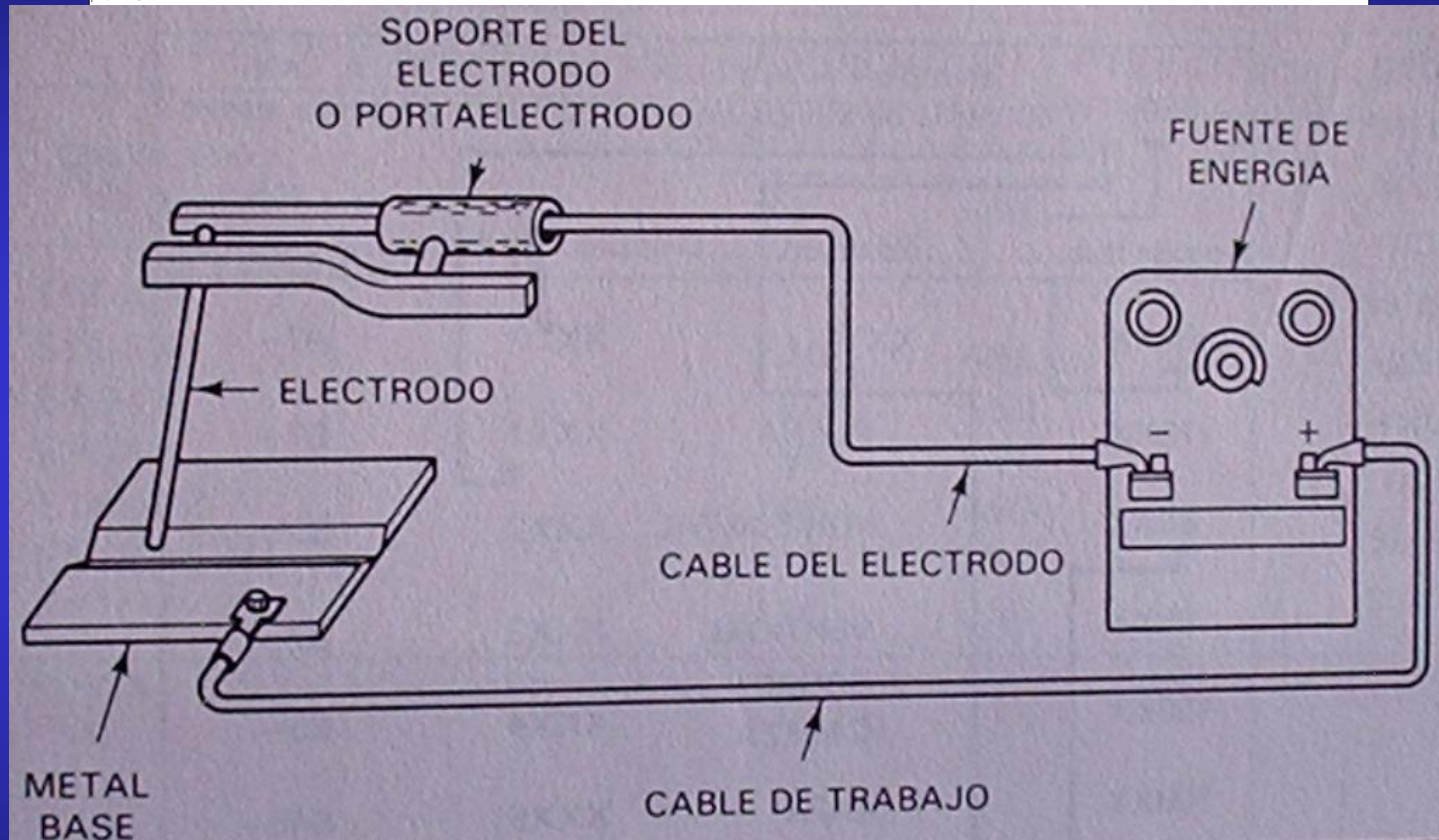



CARACTERISTICAS DE LOS ELECTRODOS

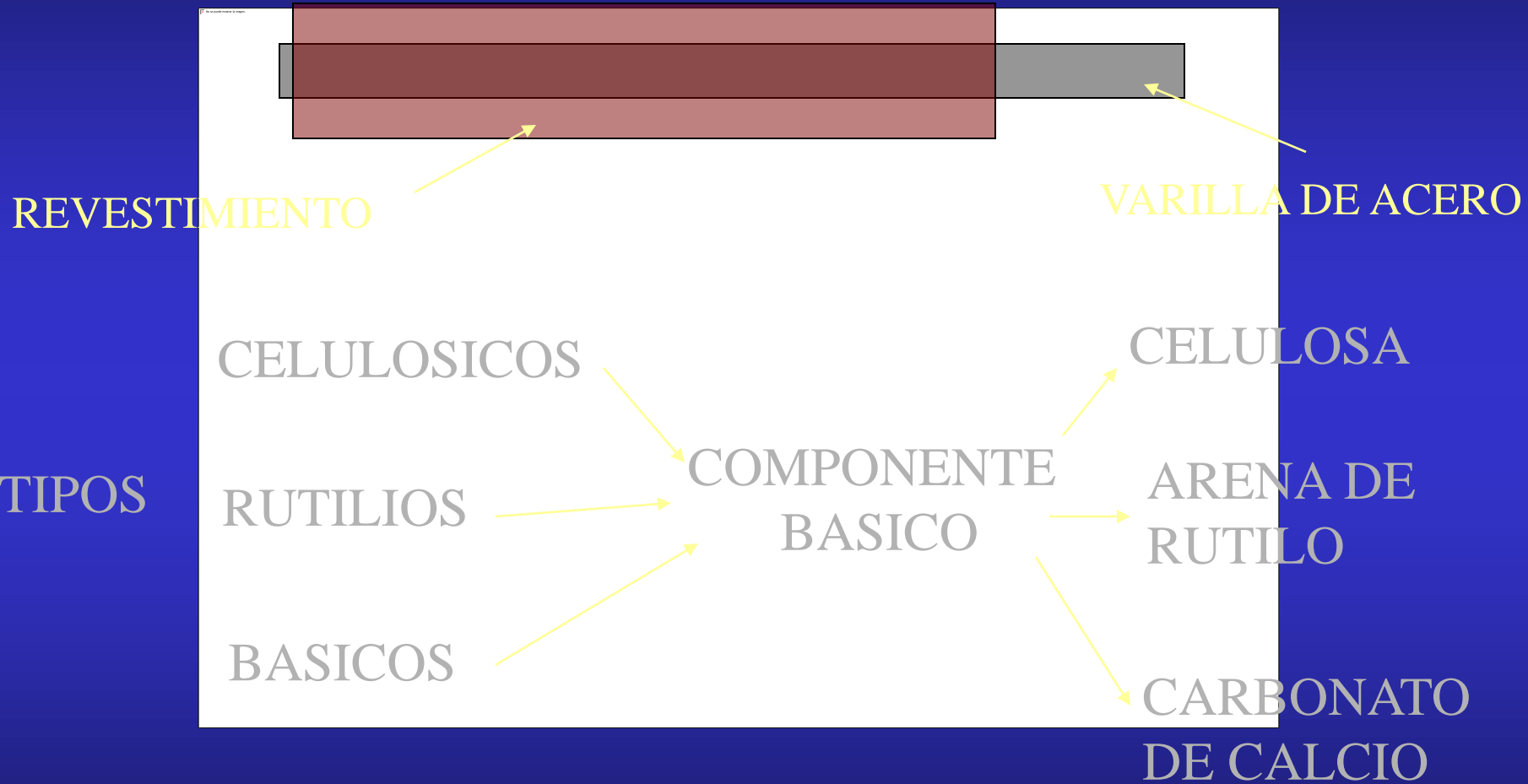



FUNCIONES DEL REVESTIMIENTO

- METAL DEPOSITADO CON CORRECTAS PROPIEDADES MECANICAS
- FACILIDAD DE OPERACIÓN Y CONTROL DE ESCORIAS
- CORDONES LIBRES DE POROS Y RESISTENTES A LA FISURACION
- FACILIDAD DE REMOCION DE ESCORIAS
- POCO CHISPORROTEO
- ARCO ESTABLE Y FACIL REENCENDIDO
- ADECUADA PENETRACION
- ALTA VELOCIDAD DE DEPOCISION
- BUENA TERMINACION SUPERFICIAL
- NO PROPORCIONAR HUMOS PICANTES O TOXICOS



NORMALIZACION

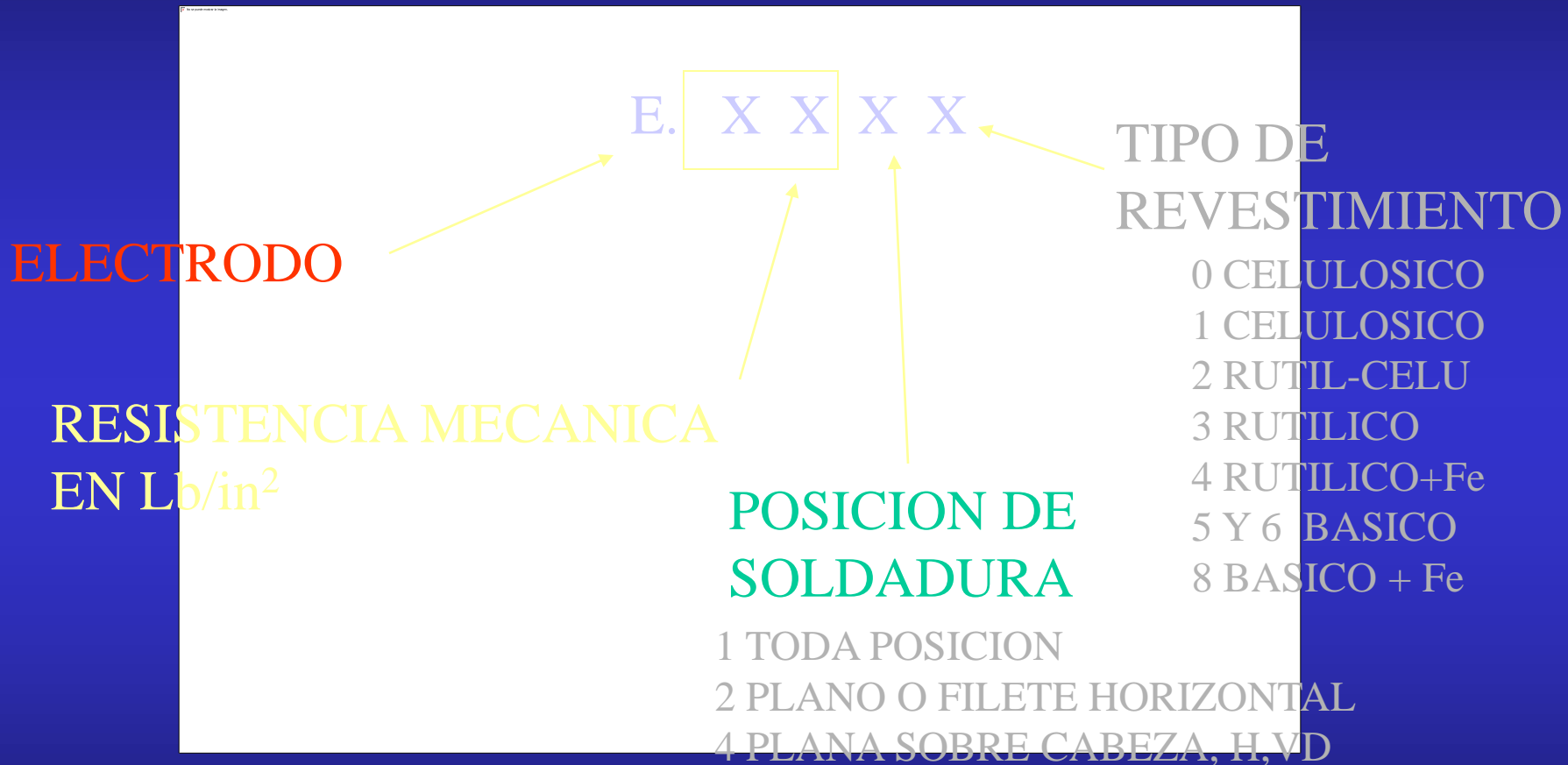



NORMALIZACION

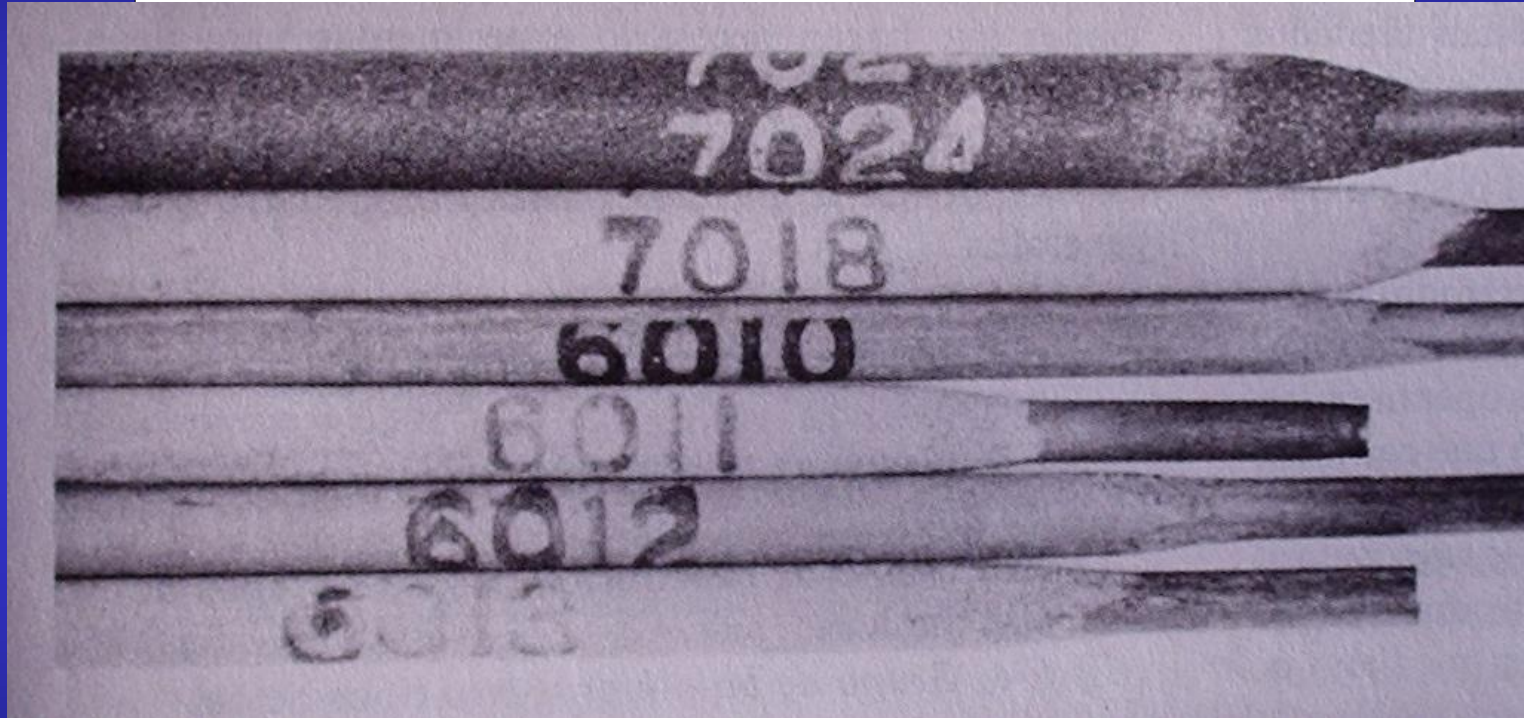



ELECTRODO REVESTIDO



ELECTRODO DE CARBON

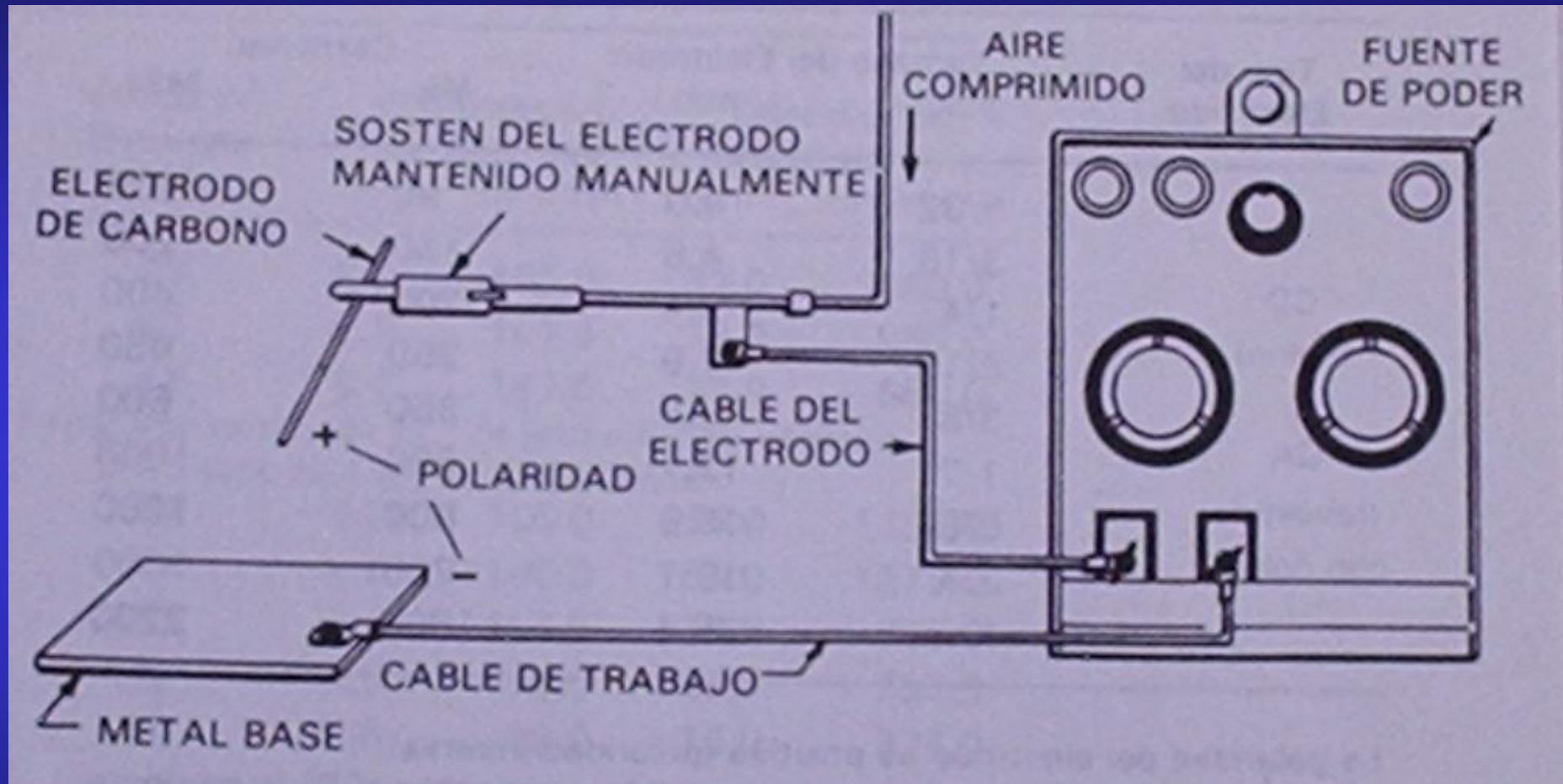

ELECTRODO DE CARBON

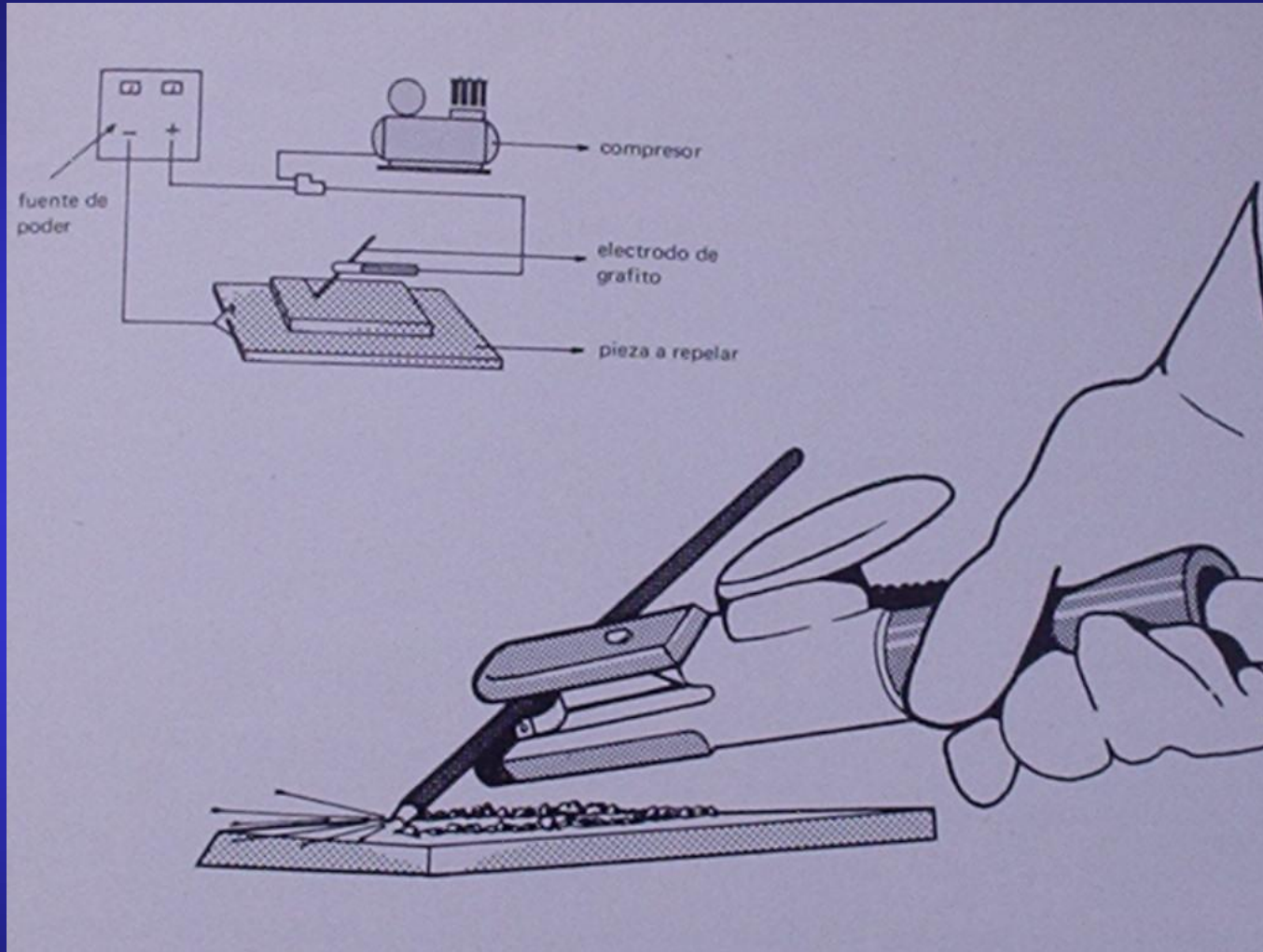



Lo clásico en soldadura MIG/MAG



Lo nuevo en soldadura MIG/MAG



Idealarc® SP 250 I

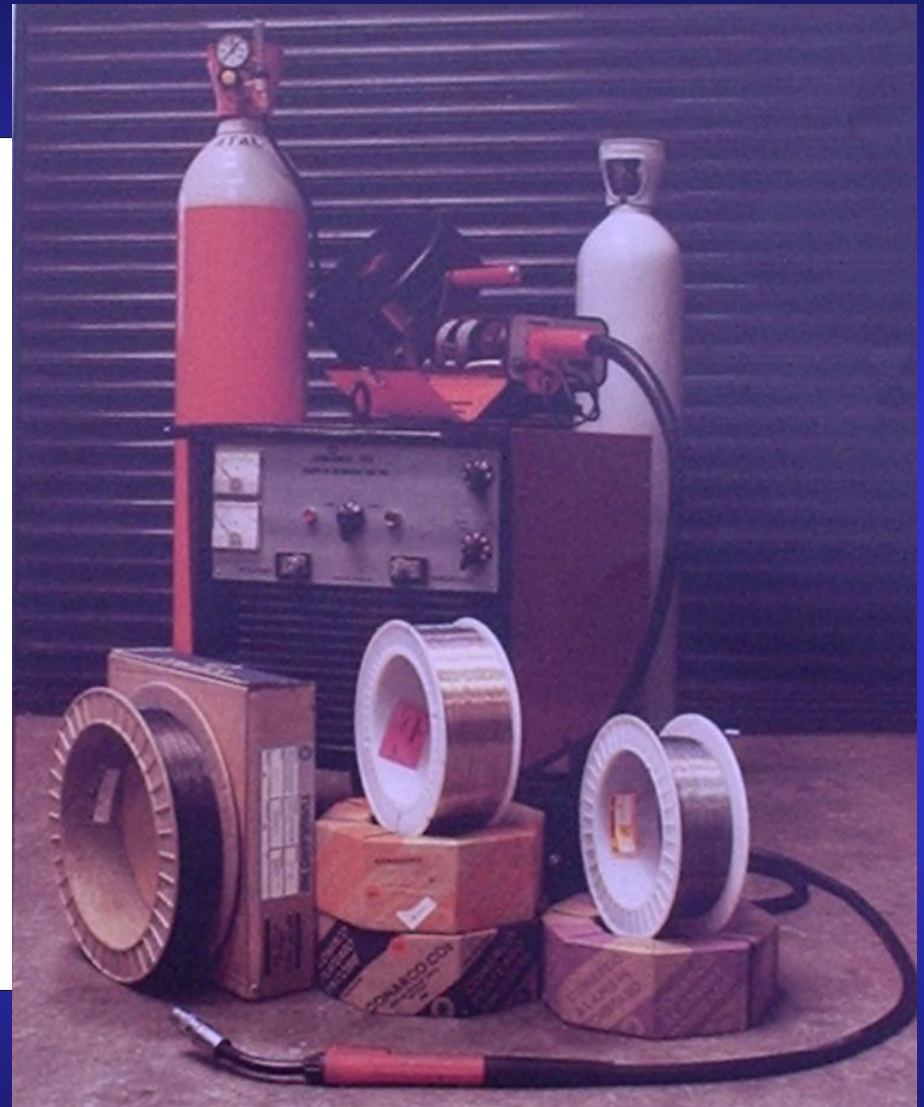

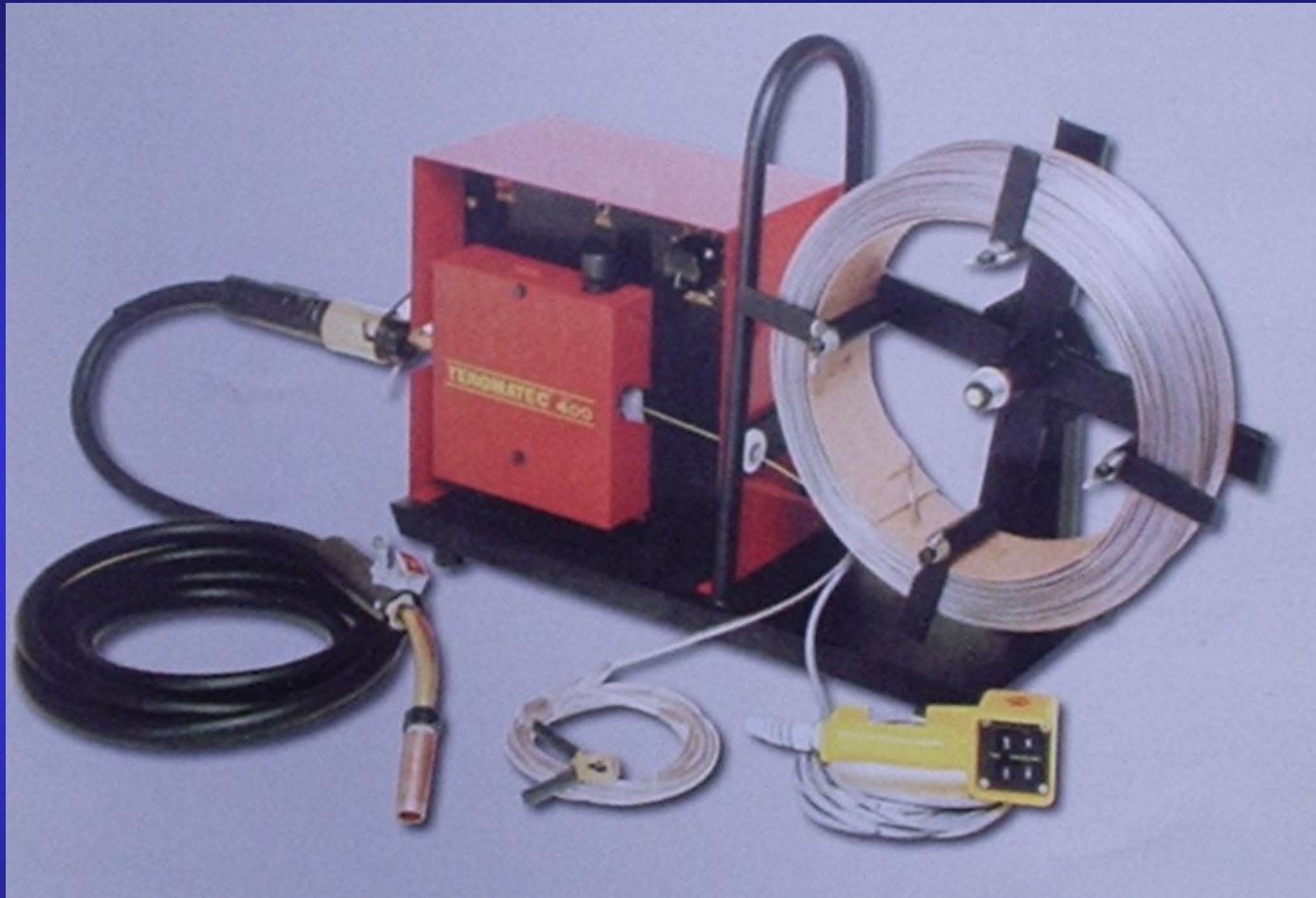

GAS Y ALAMBRE MACIZO

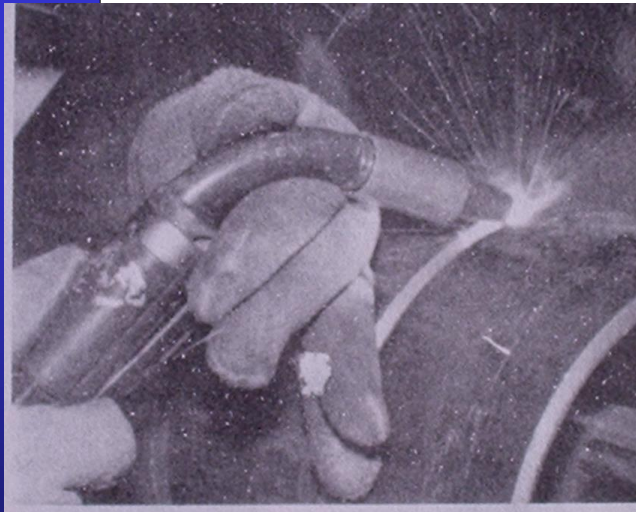
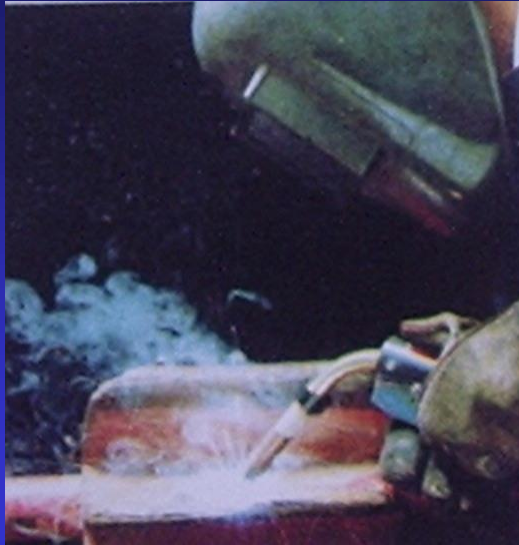

GAS Y ALAMBRE MACIZO

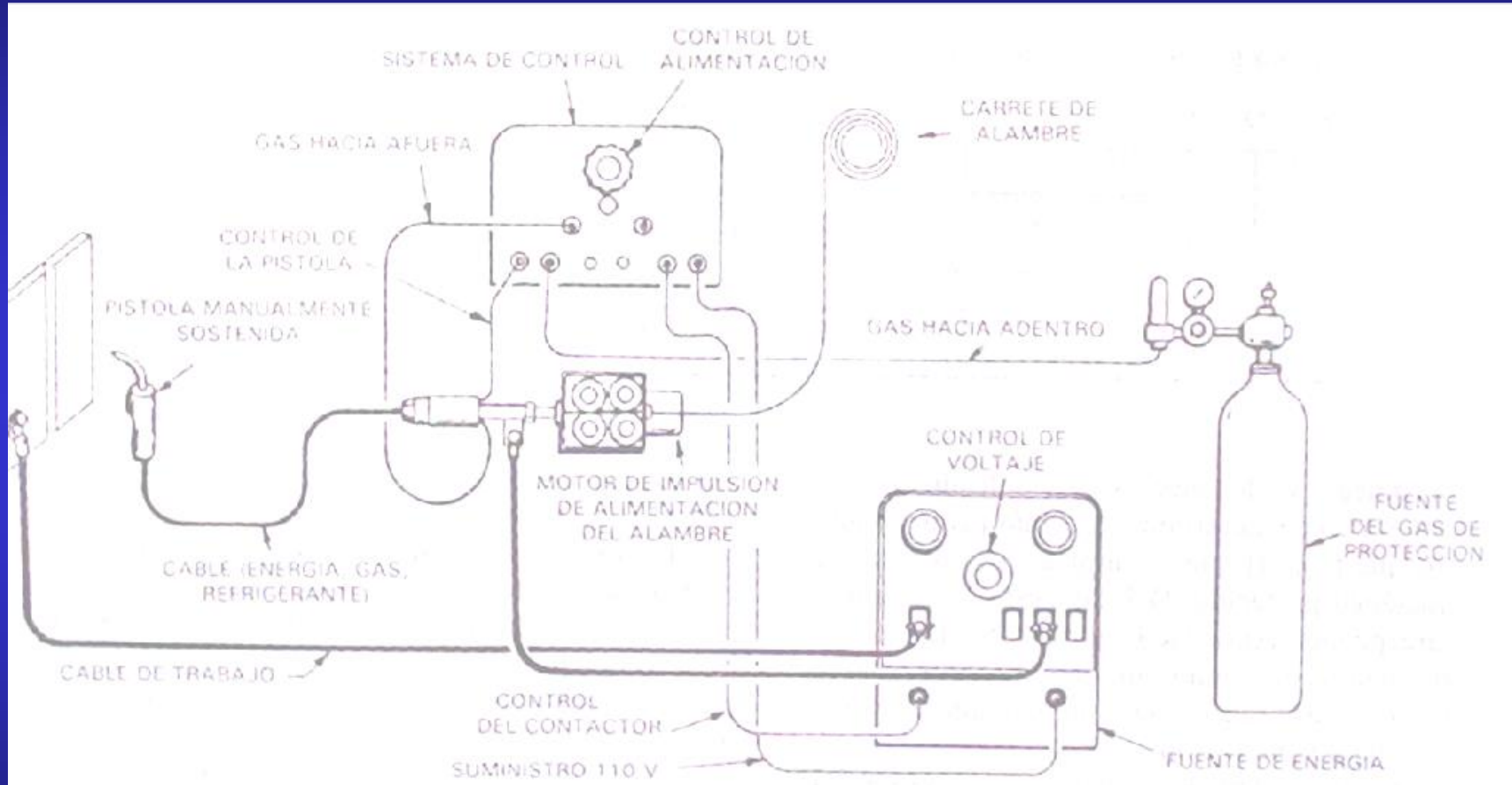

GAS Y ALAMBRE MACIZO

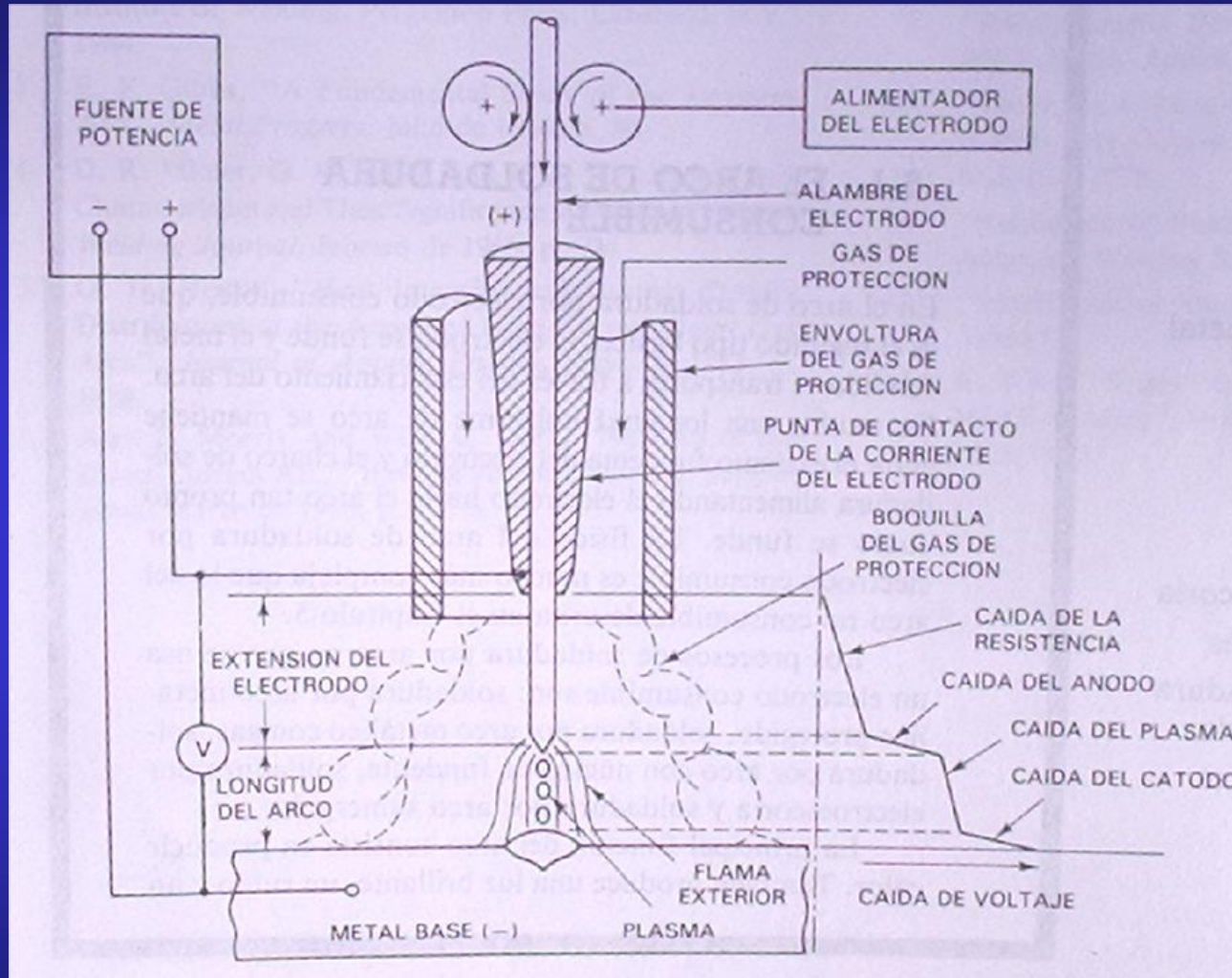

GAS Y ALAMBRE MACIZO

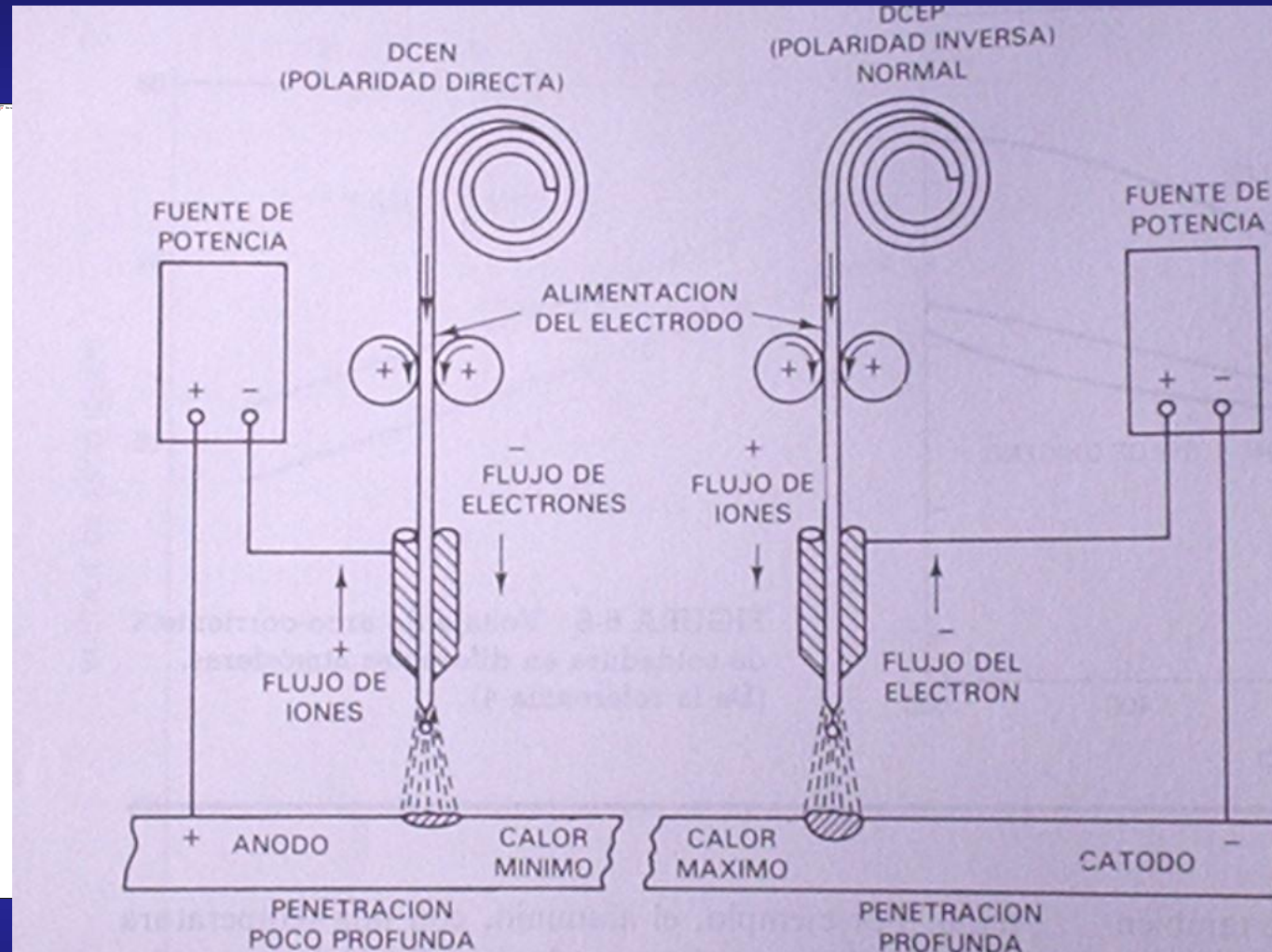



MODO DE TRANSFERENCIA DEL MATERIAL DE APORTE

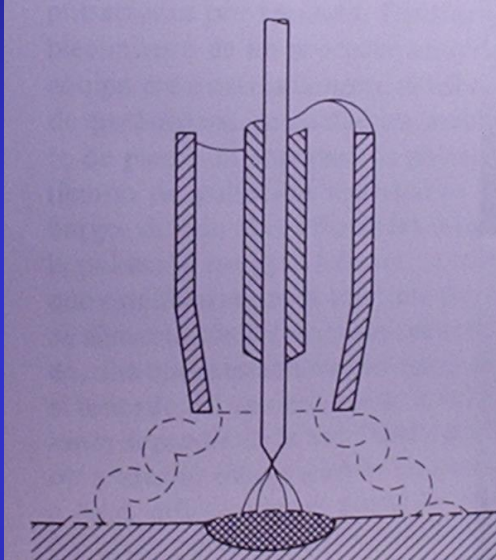

CORTO CIRCUITO

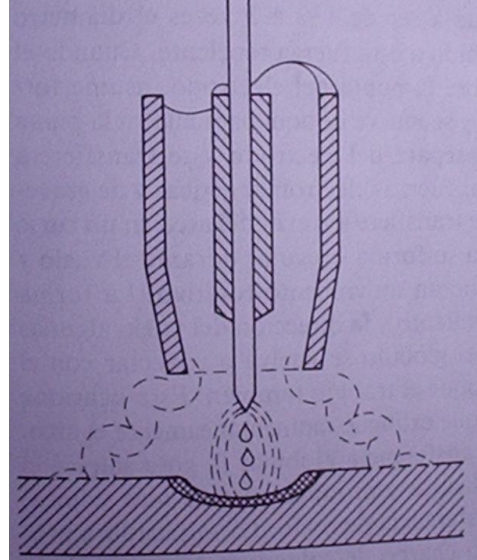

ROCIO

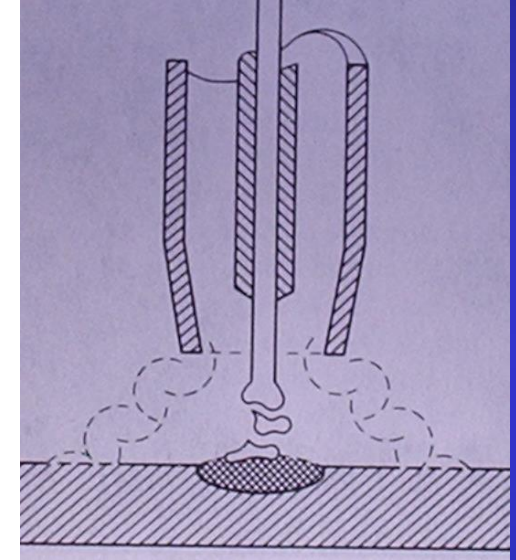

GLOBULAR

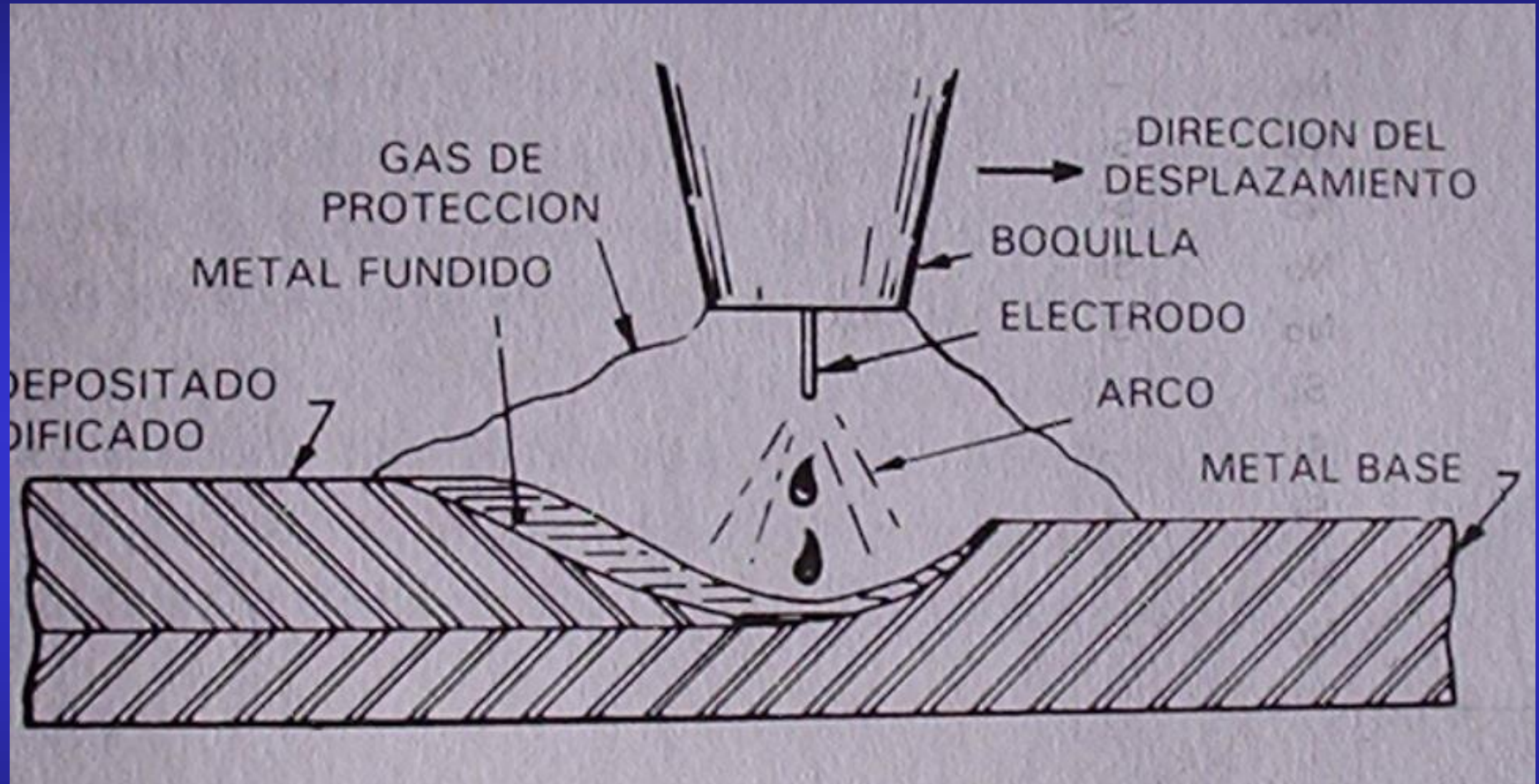

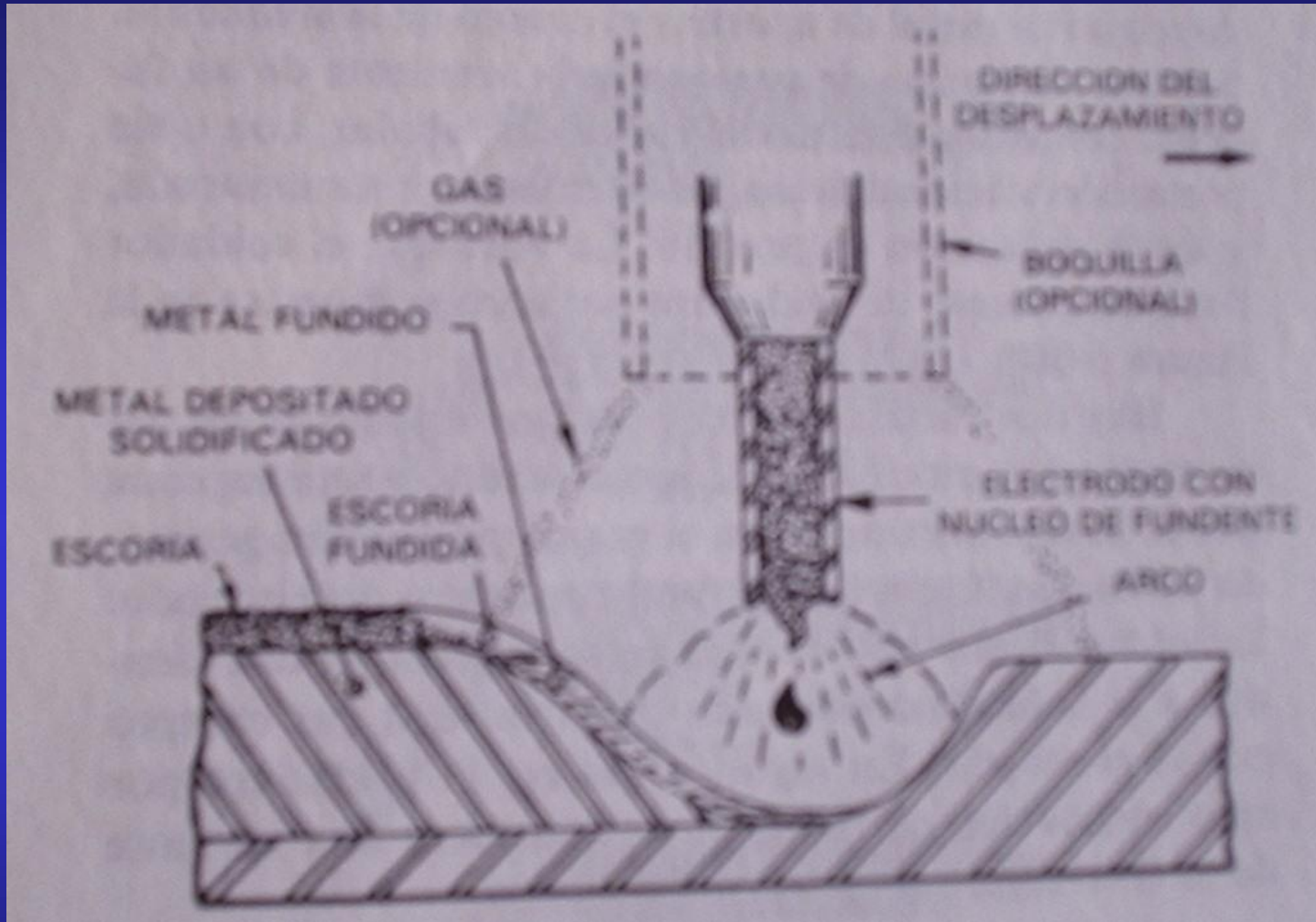

ALAMBRE RELLENO

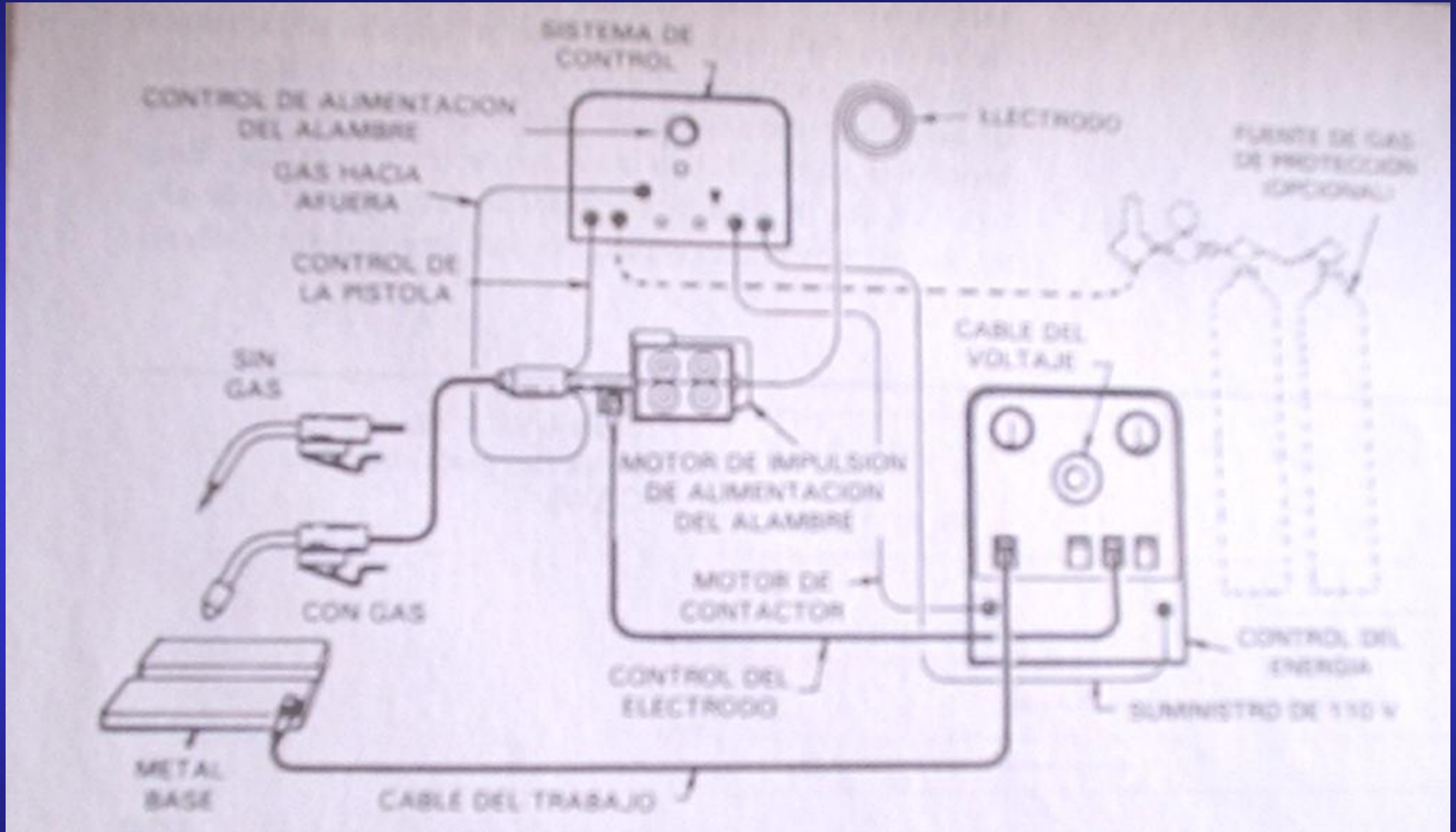

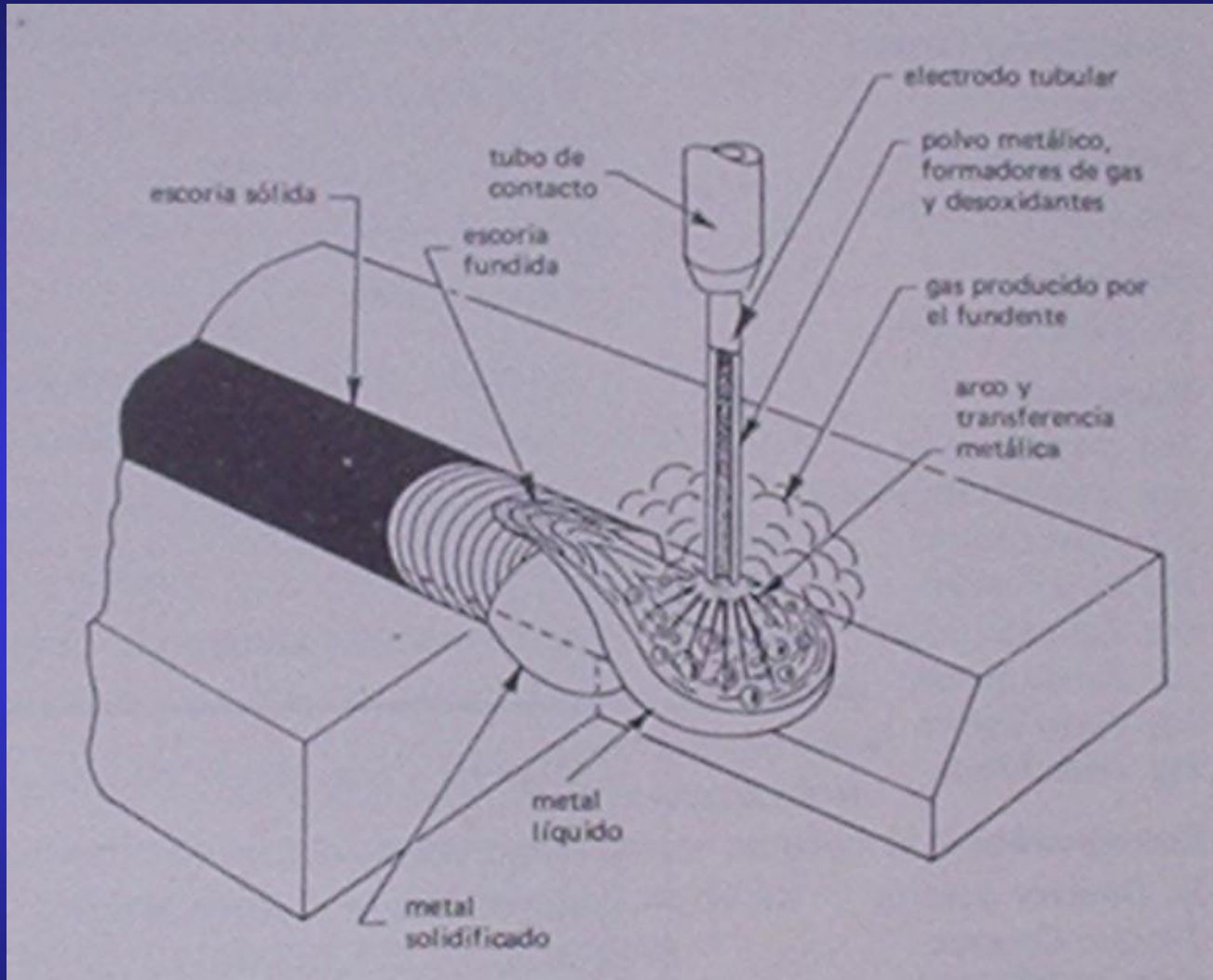

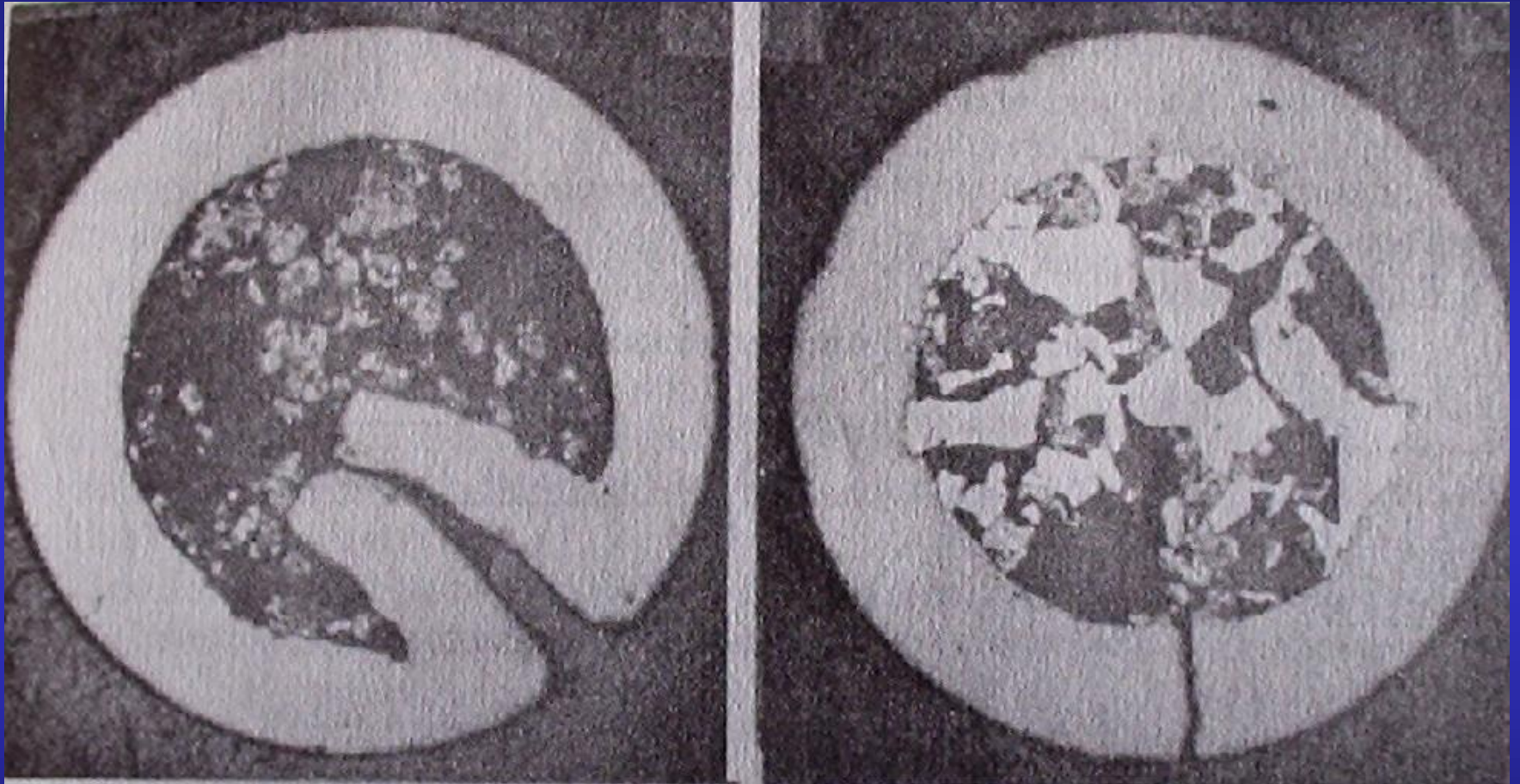

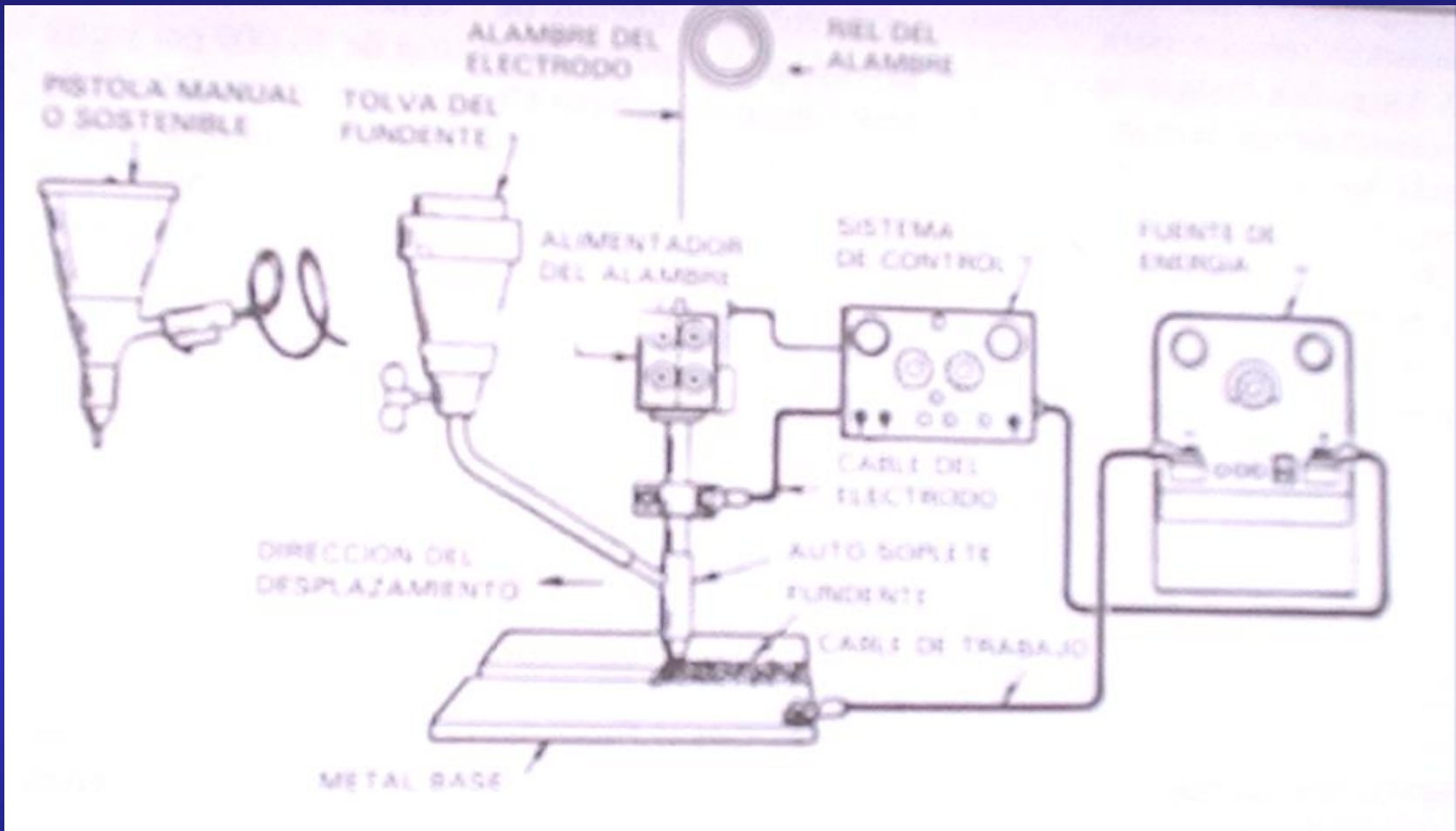

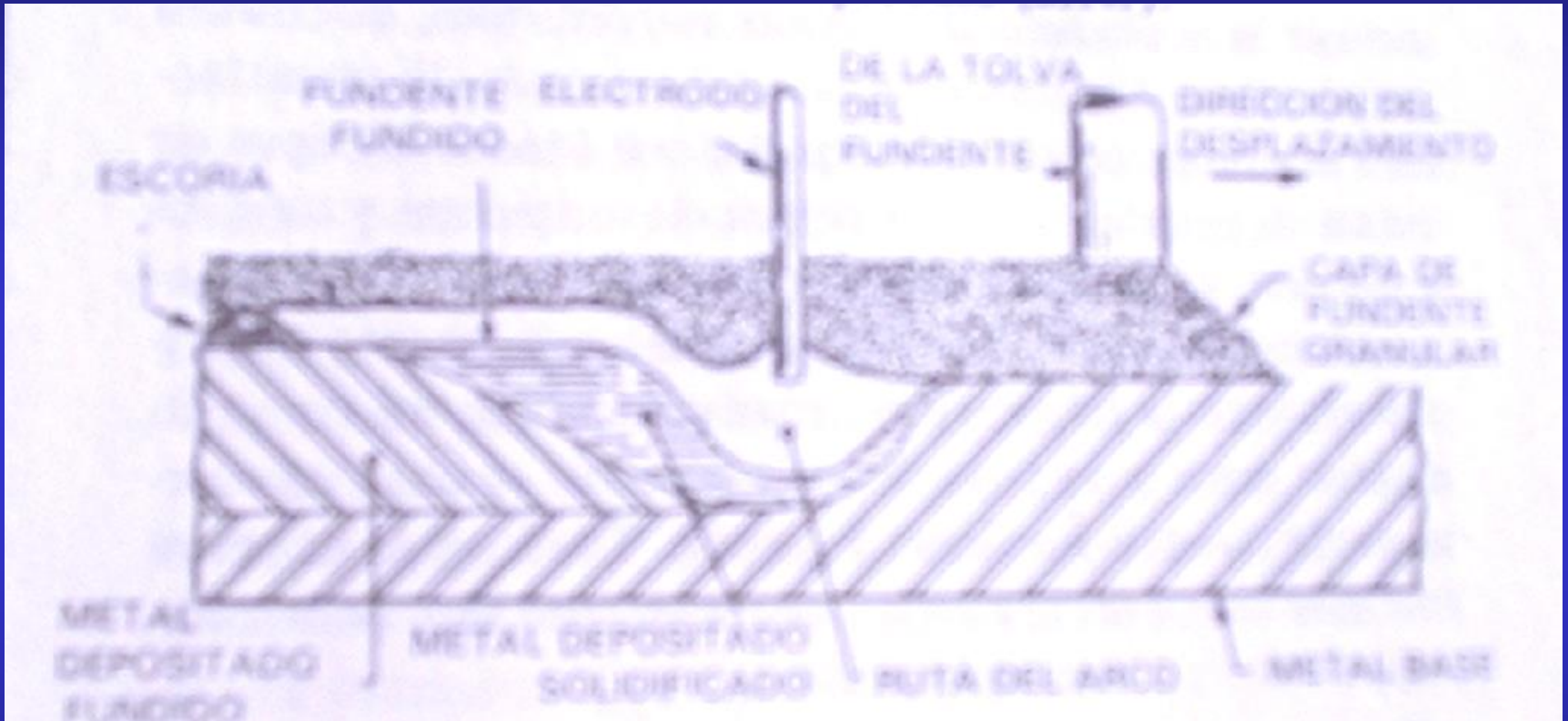

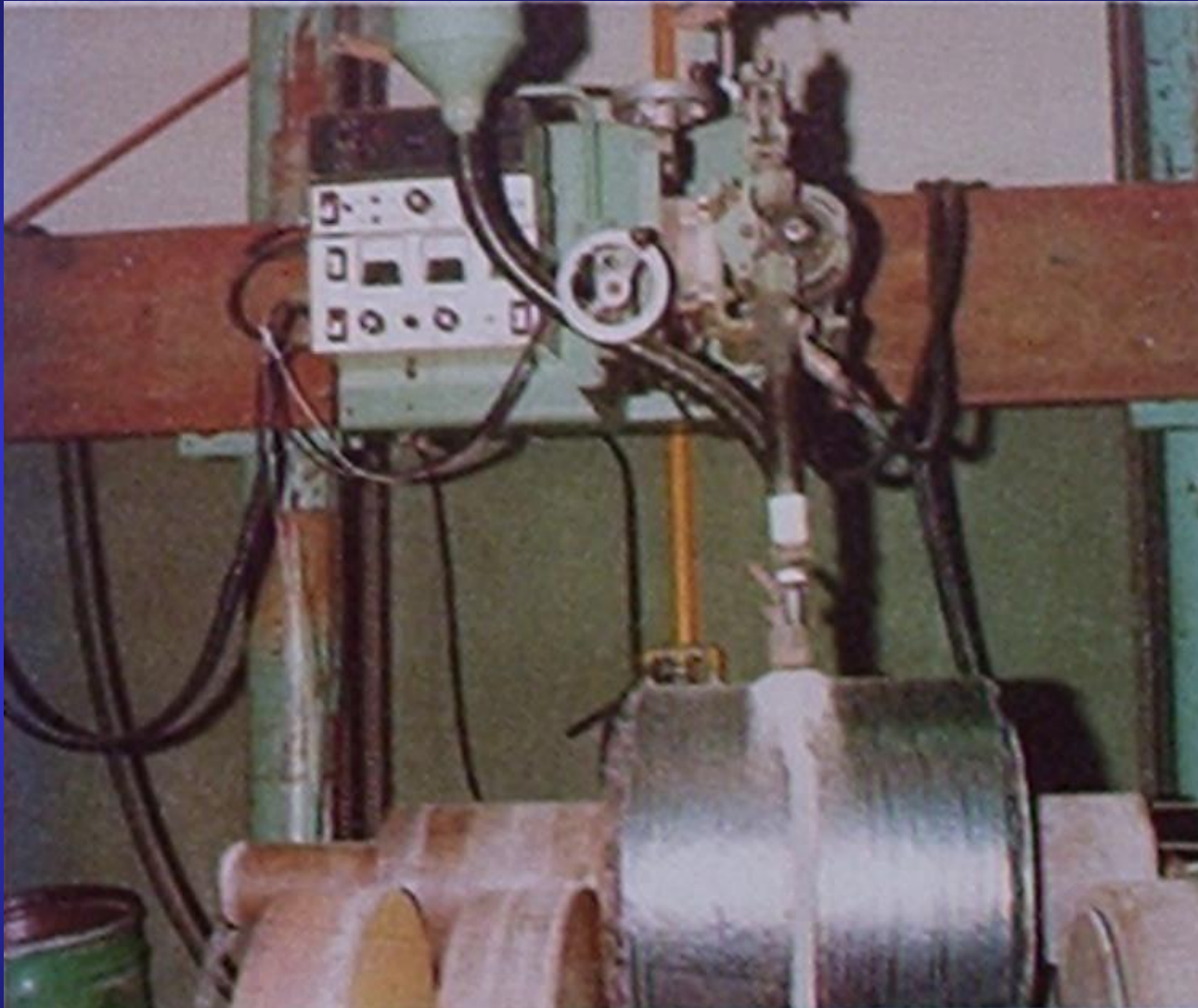



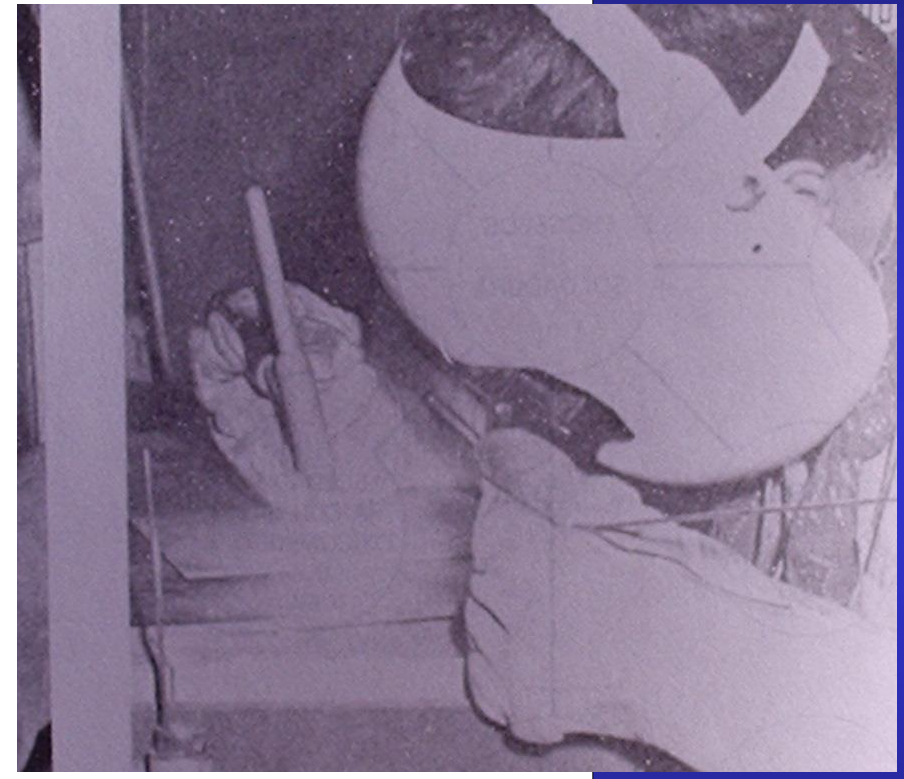
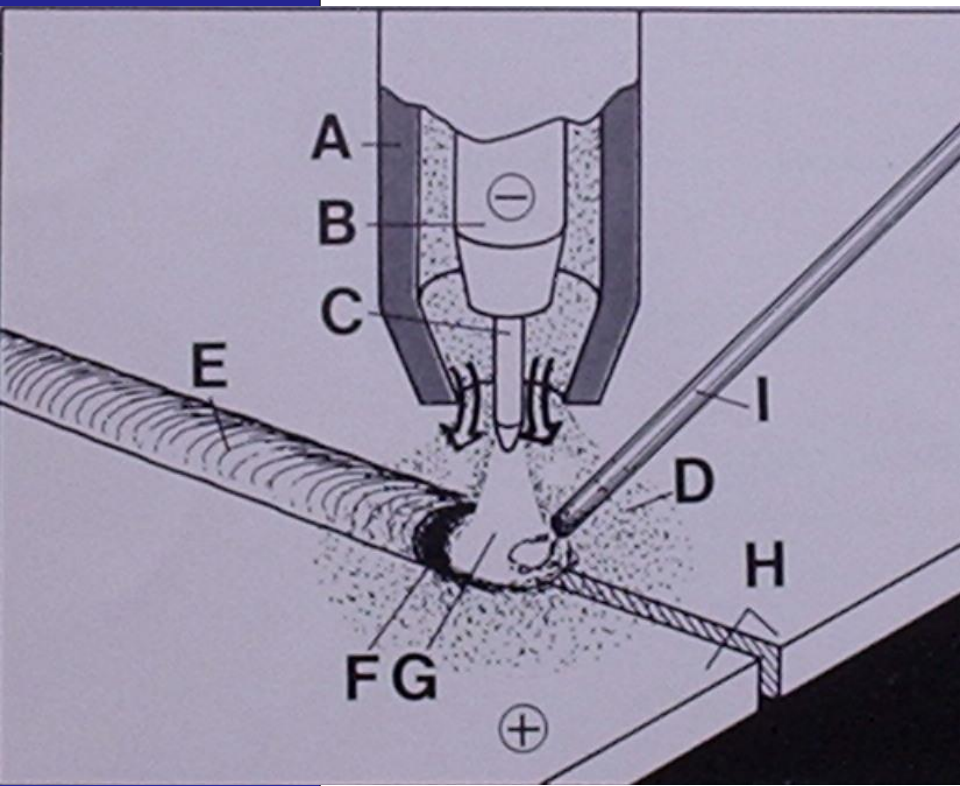

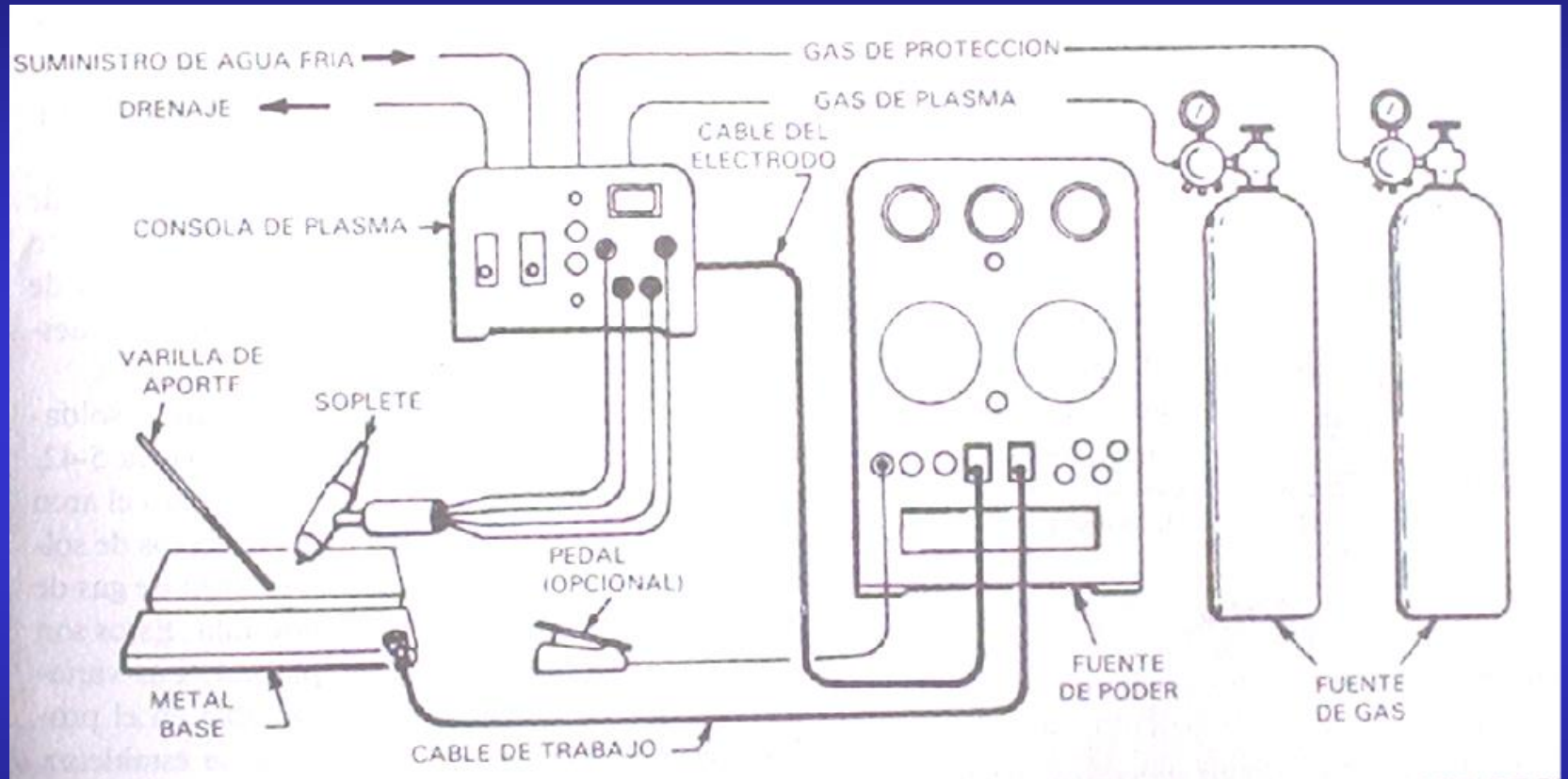

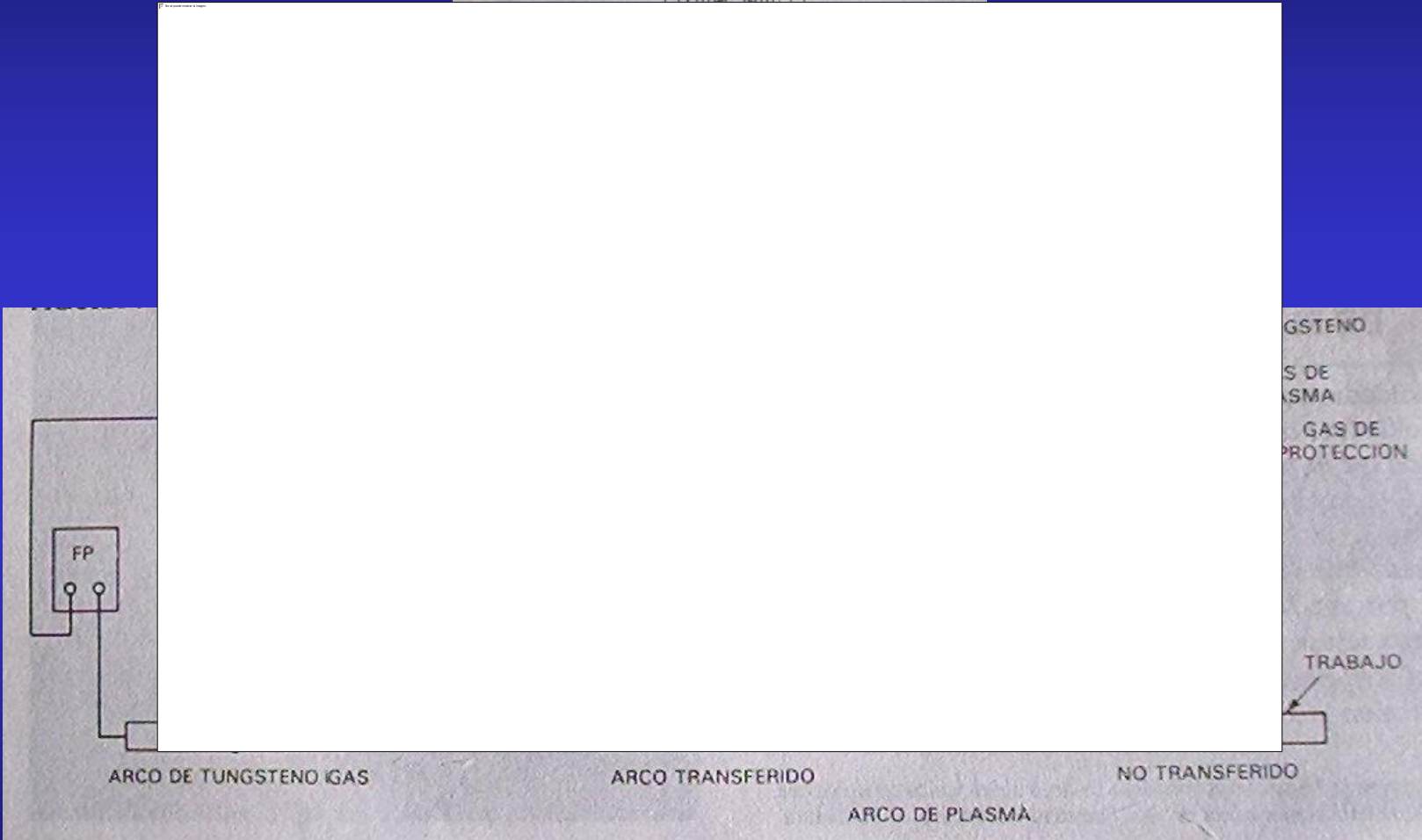

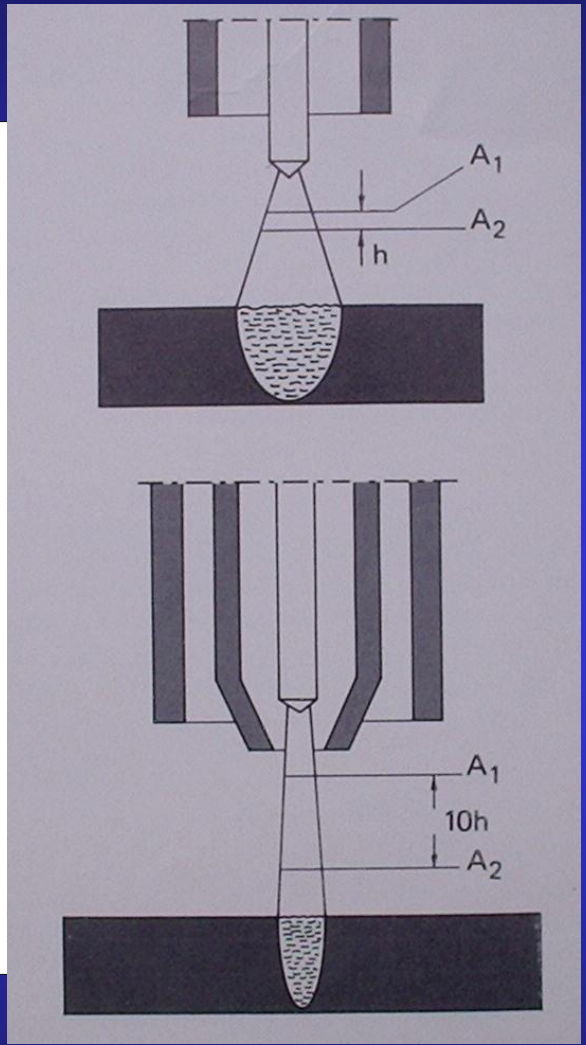
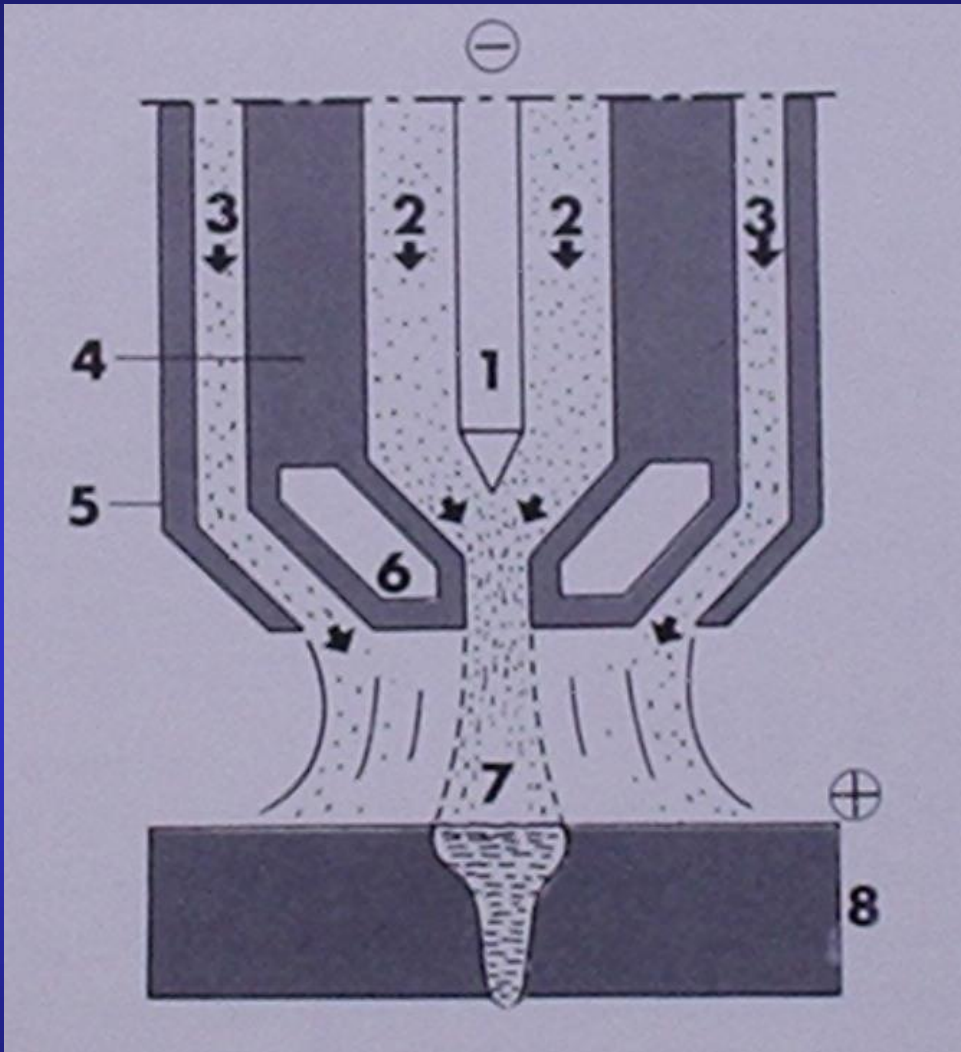

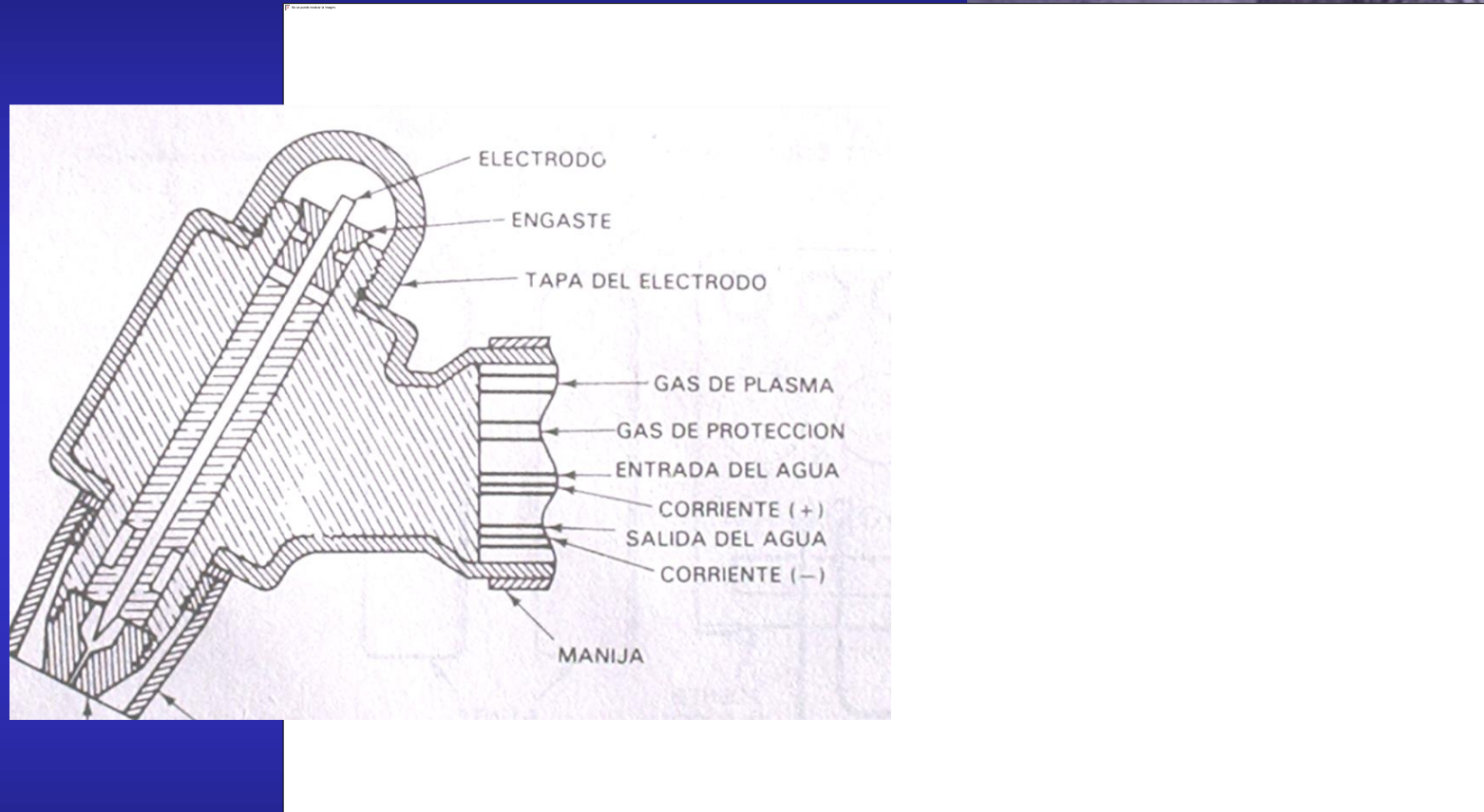

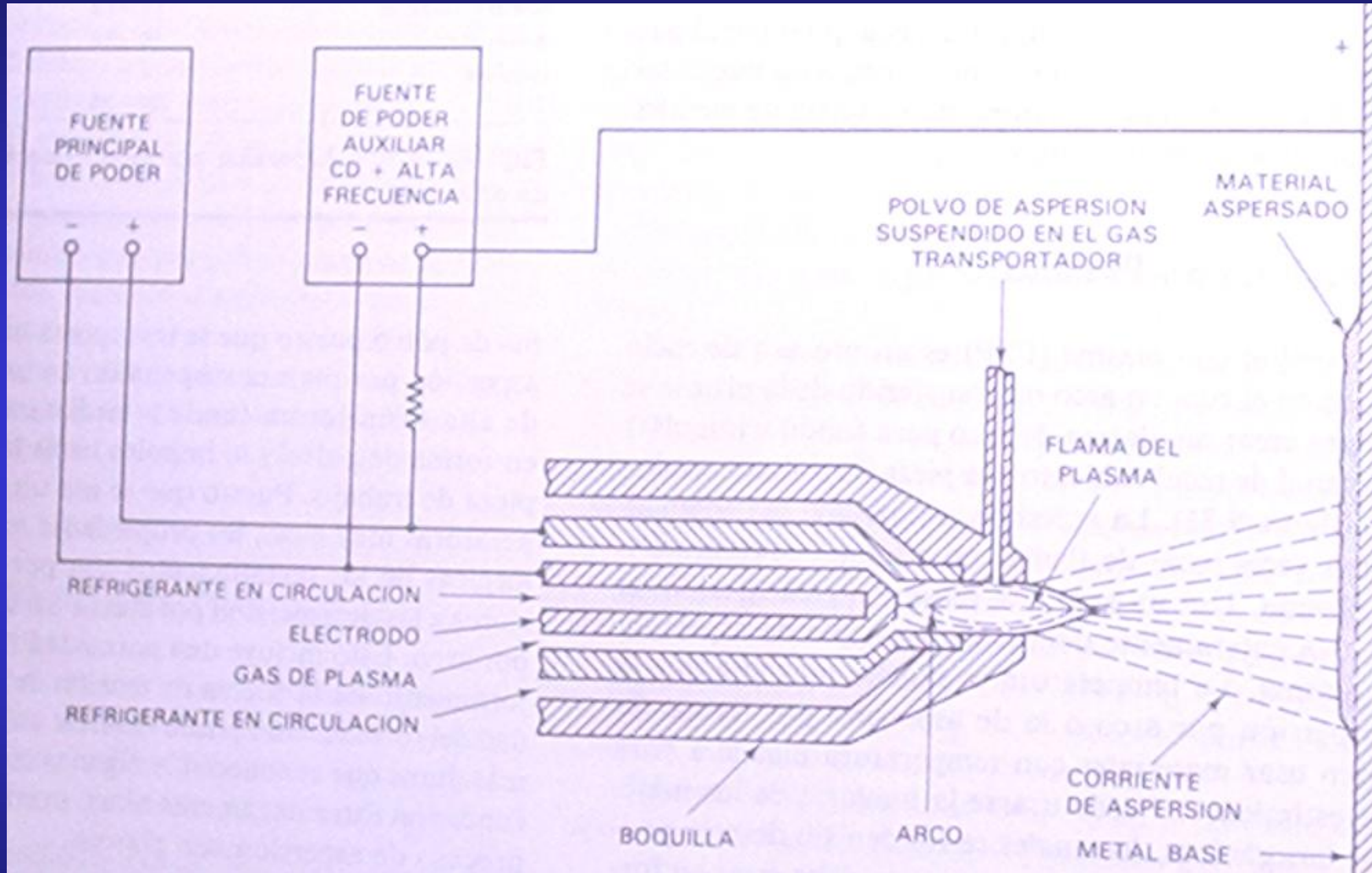

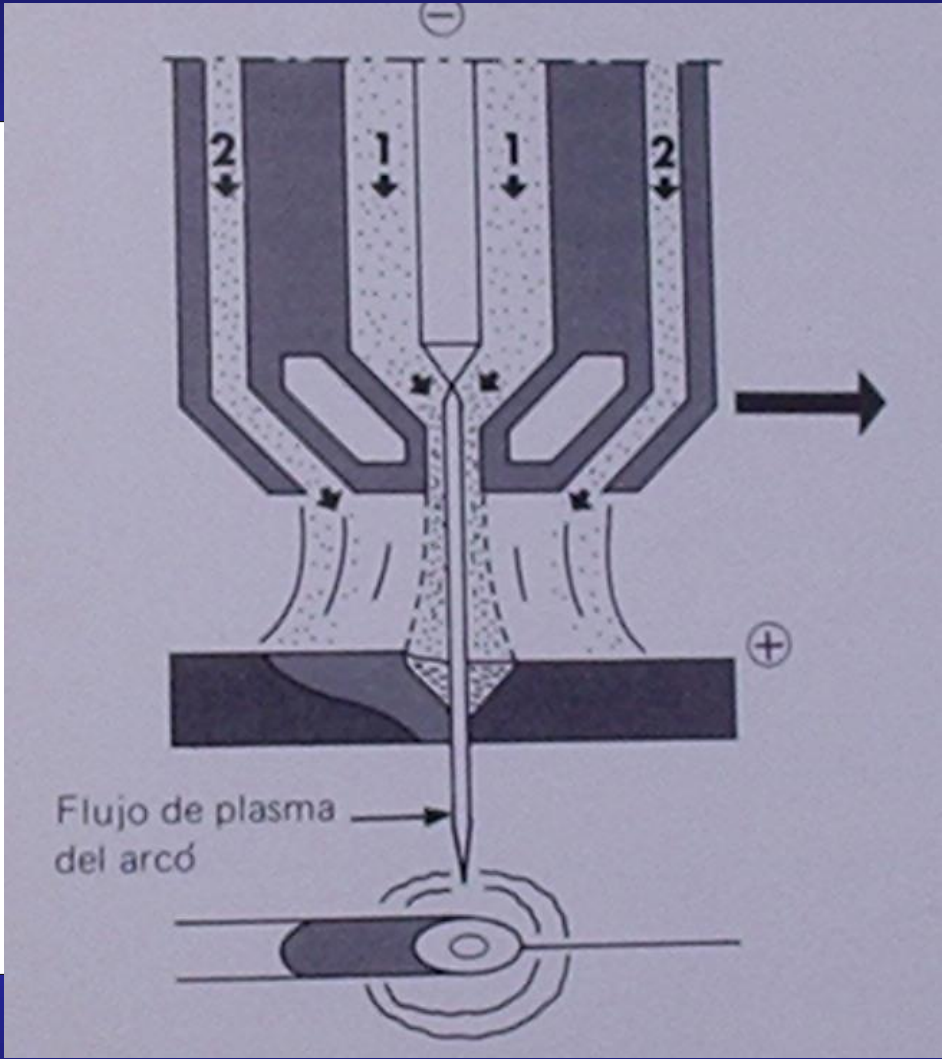

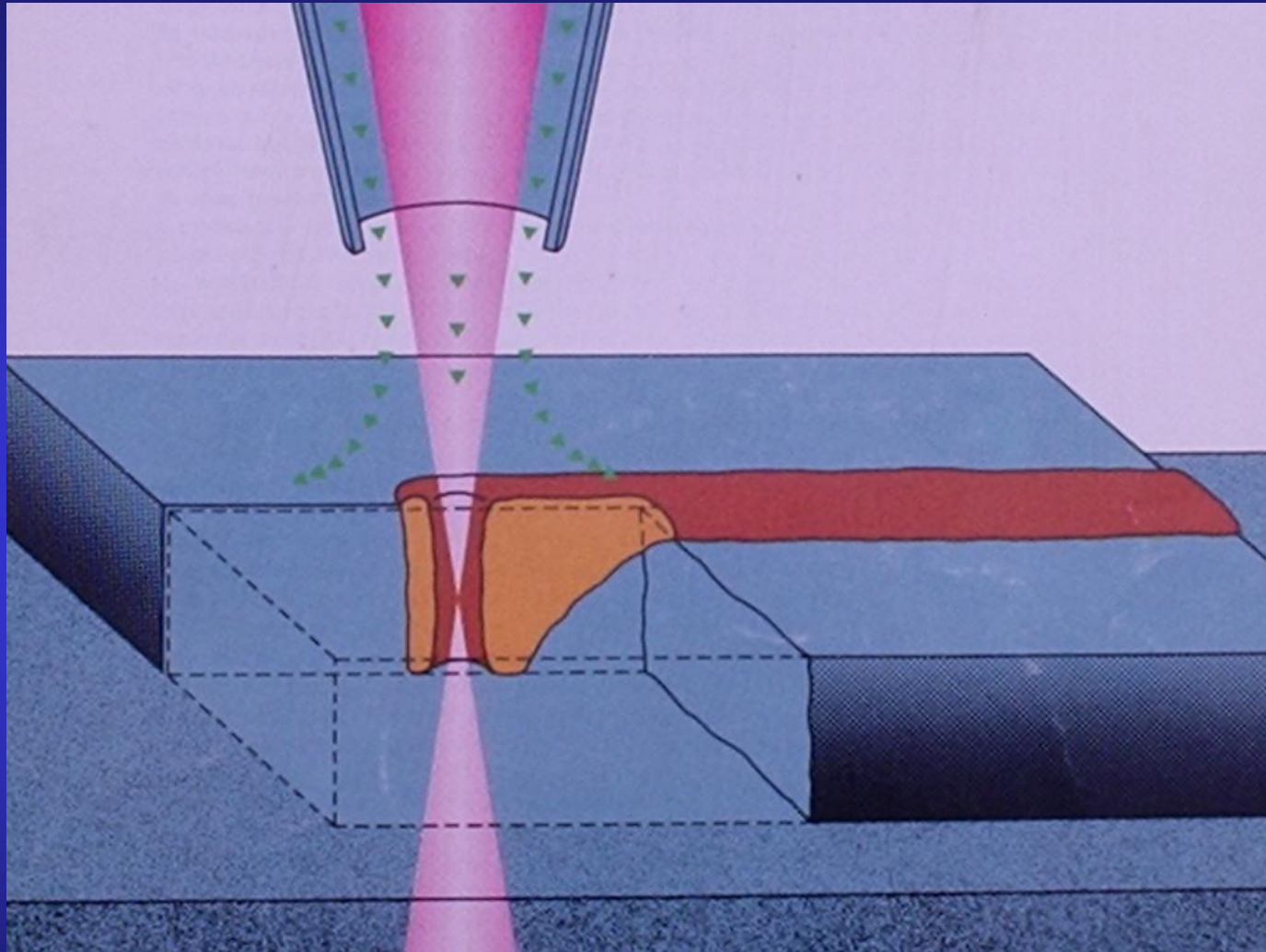

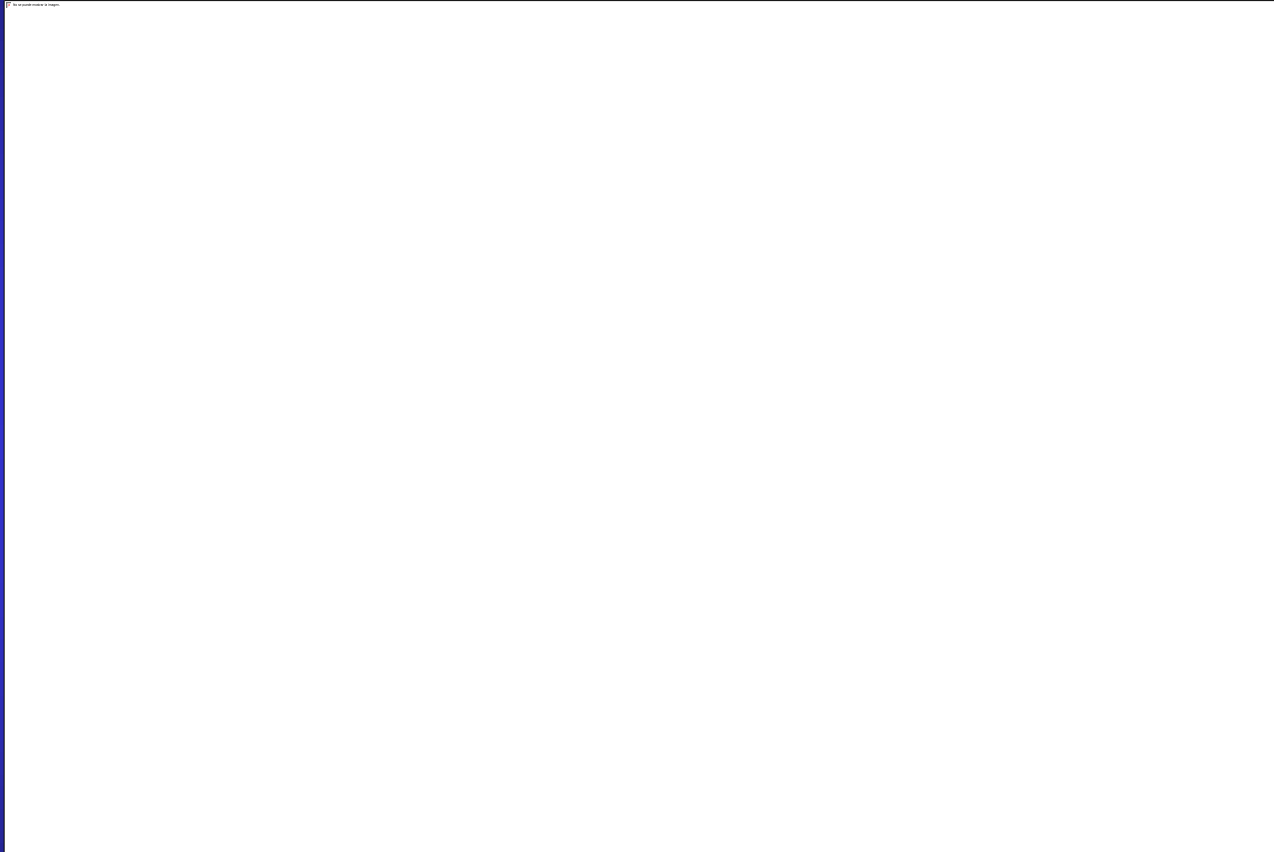

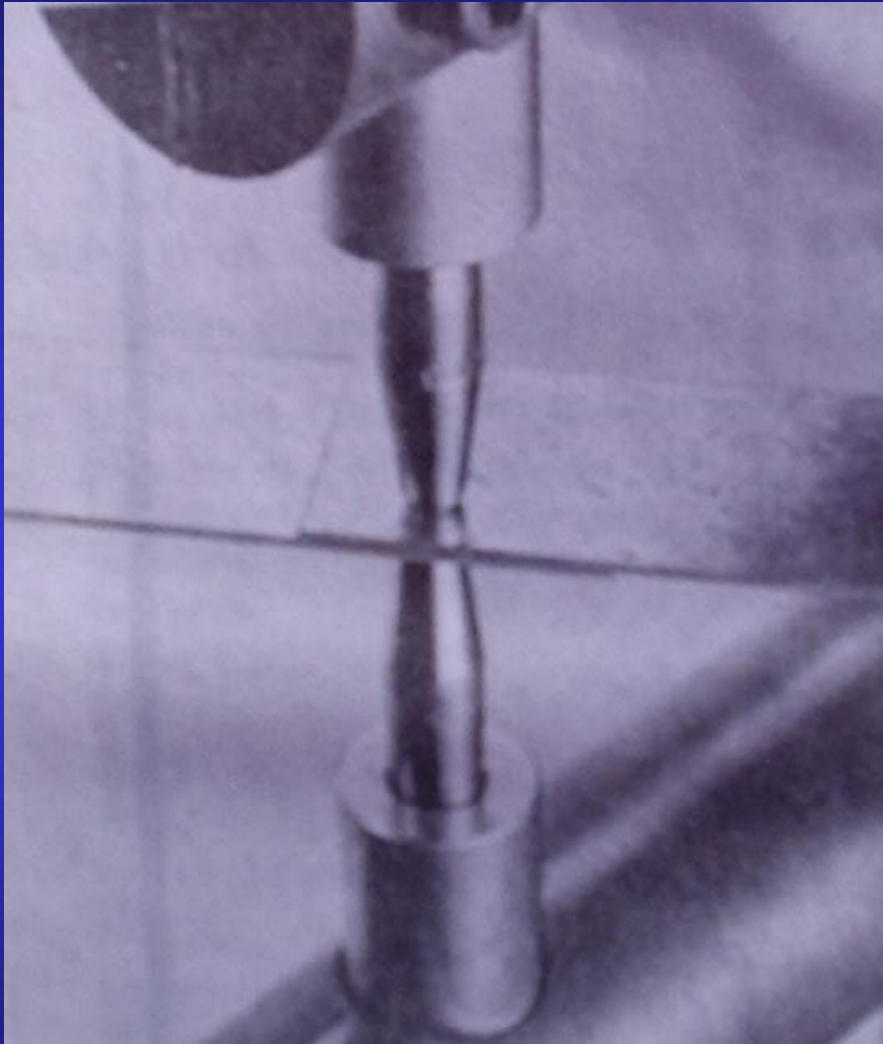



POSICION DE SOLDADURA

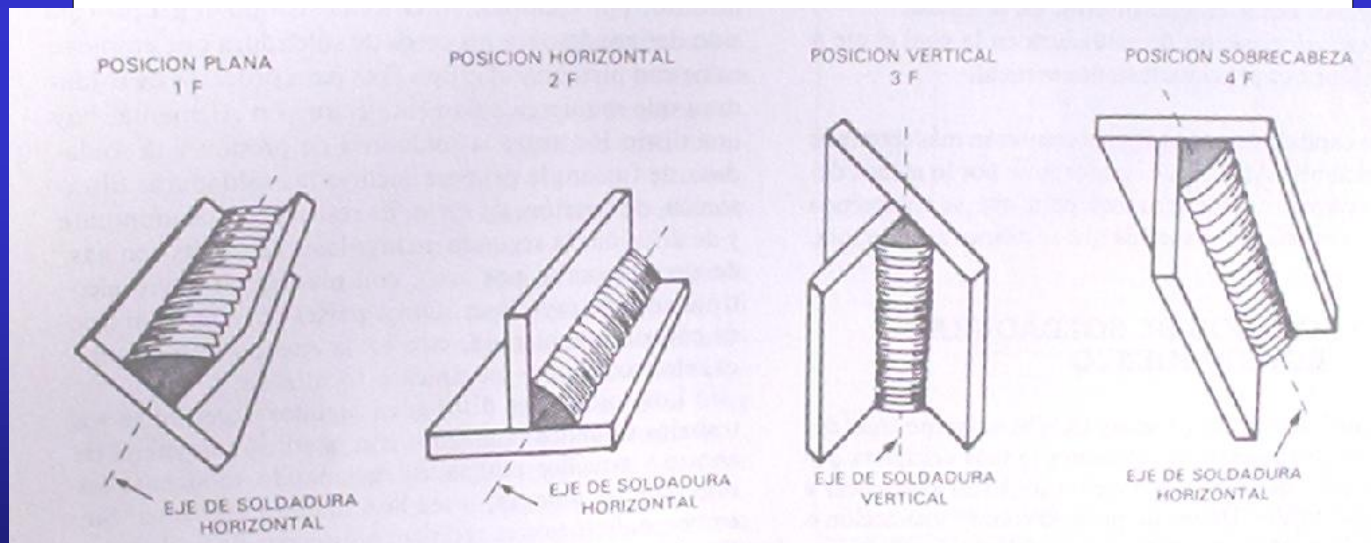
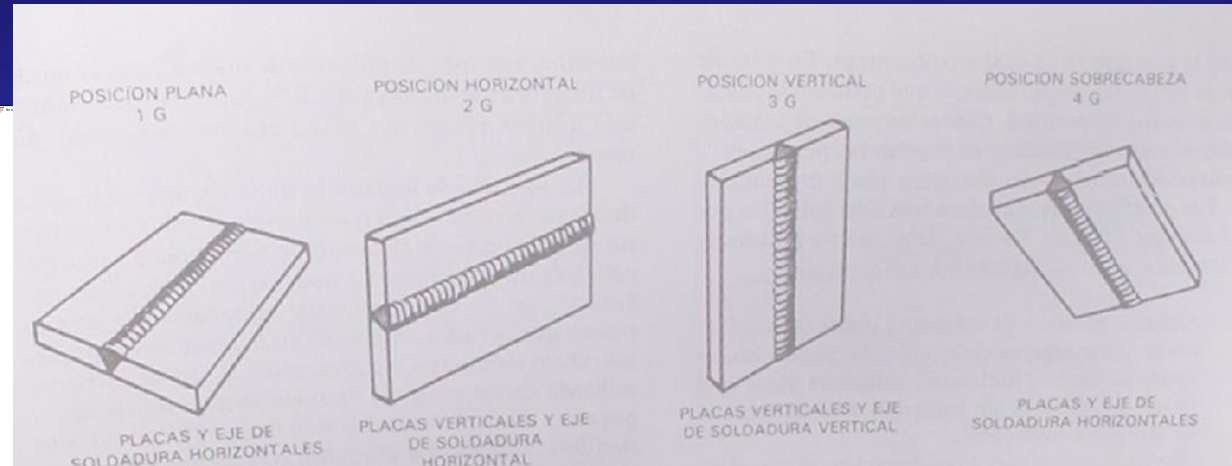

POSICION DE SOLDADURA

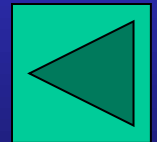
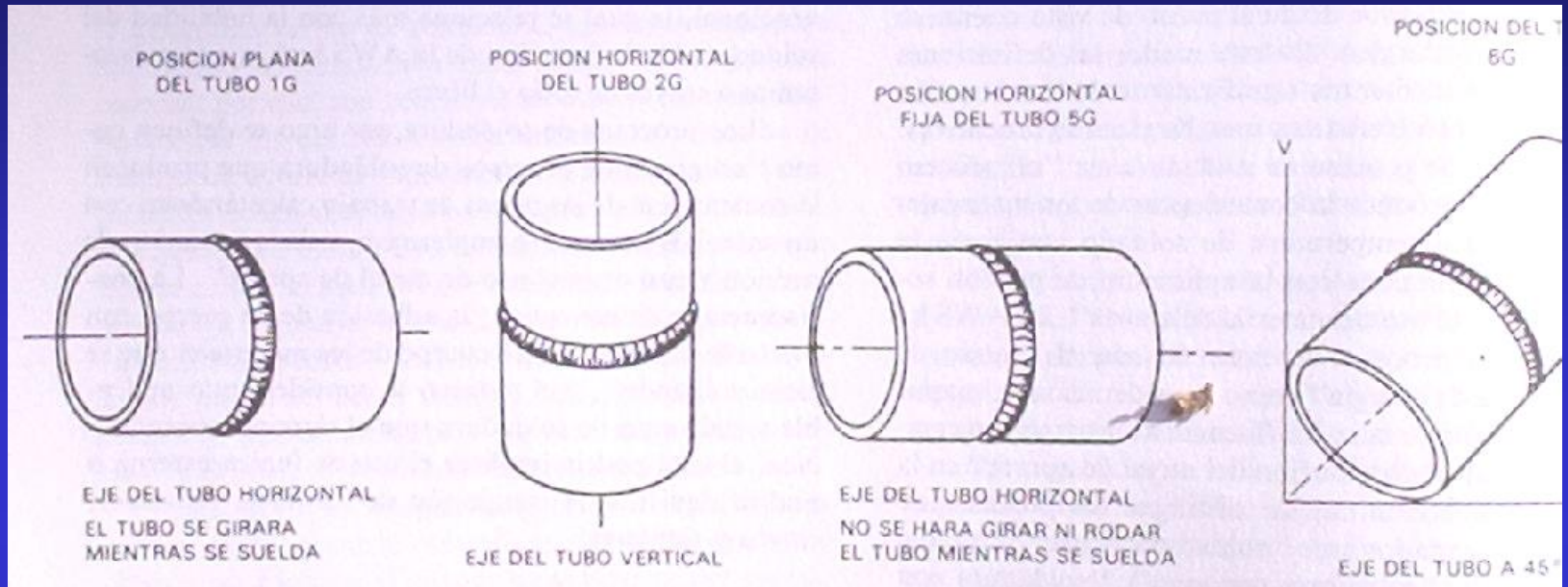

PROCESOS DE CORTE

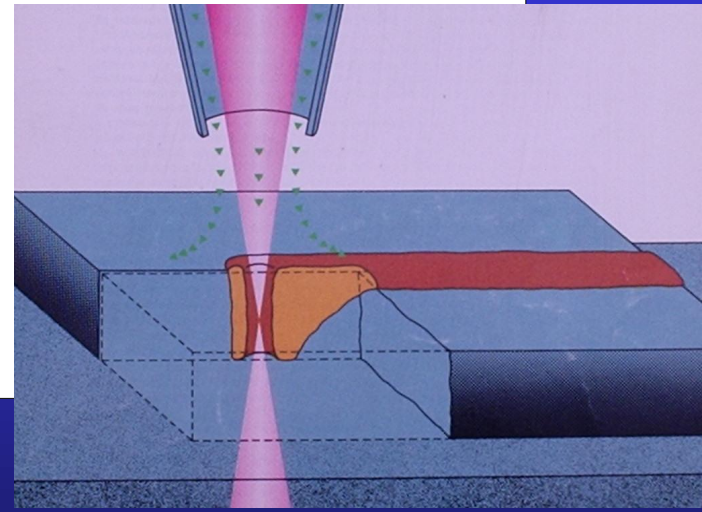
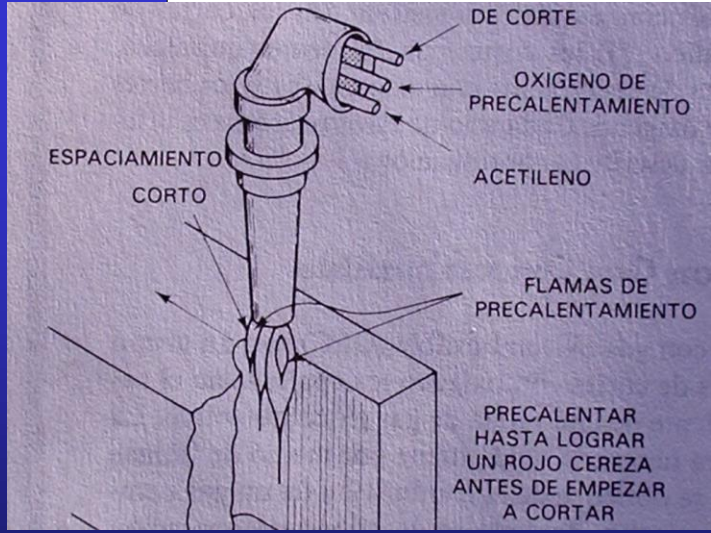
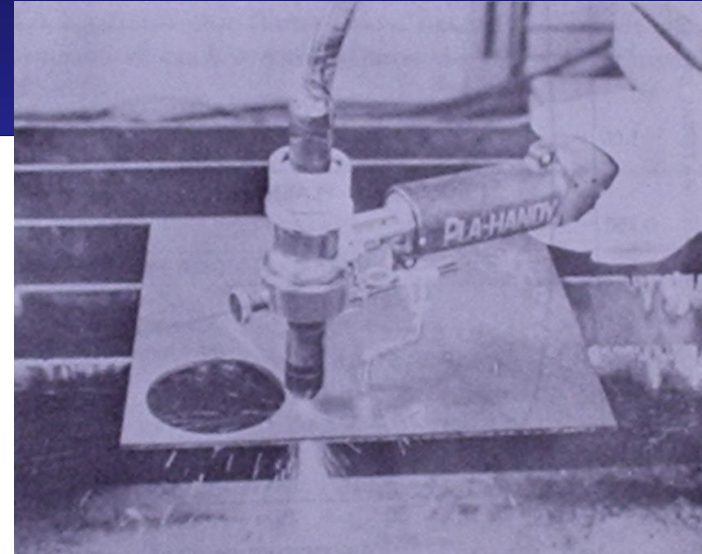
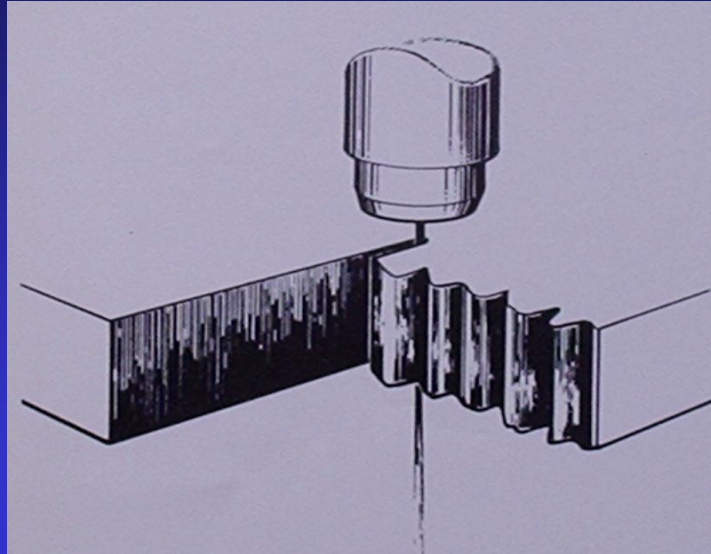

PROCESOS DE CORTE

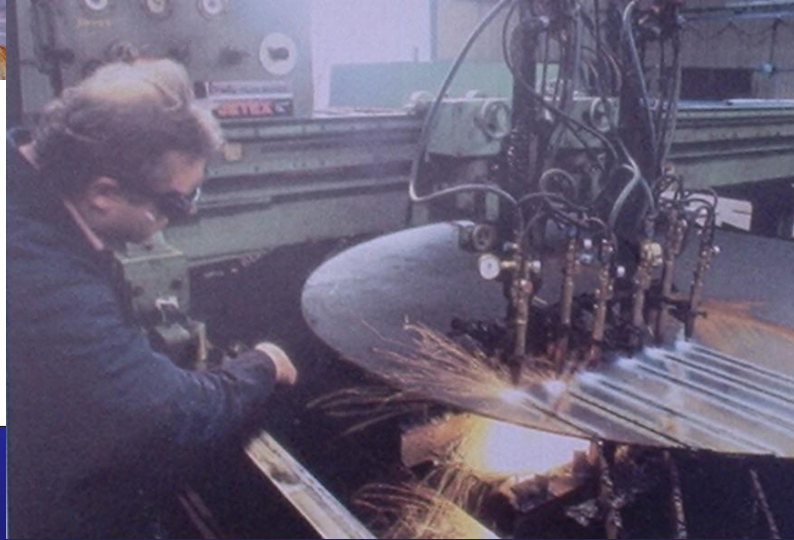
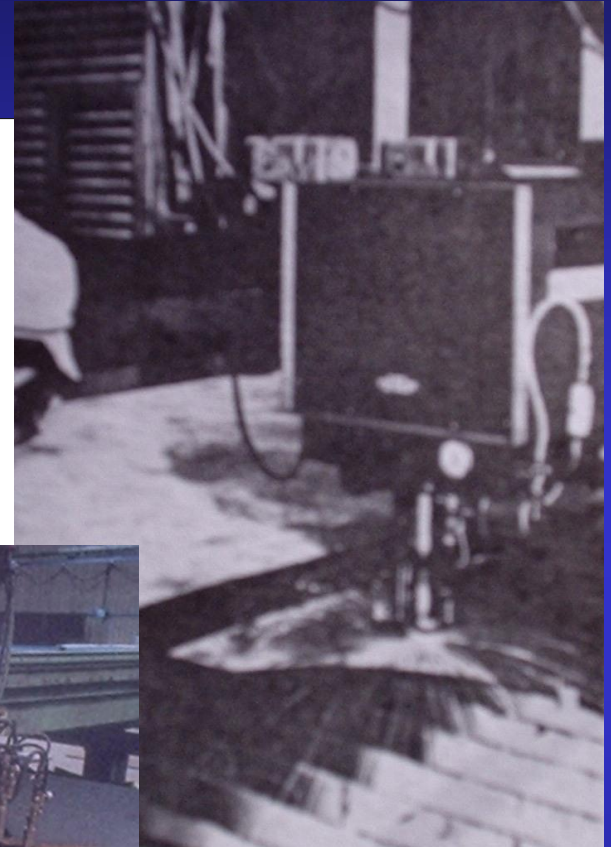
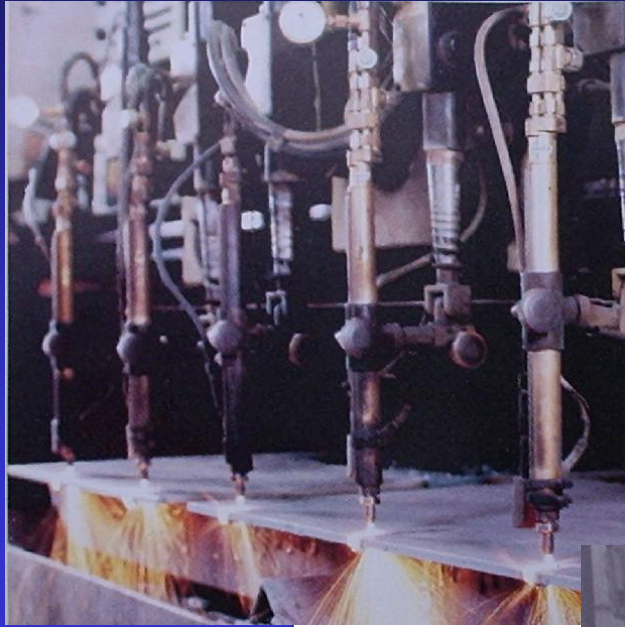

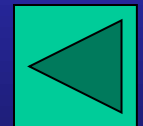
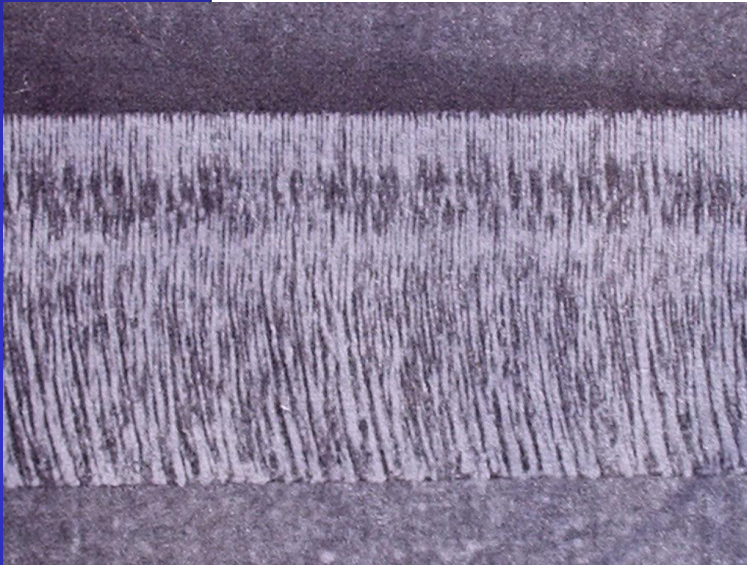

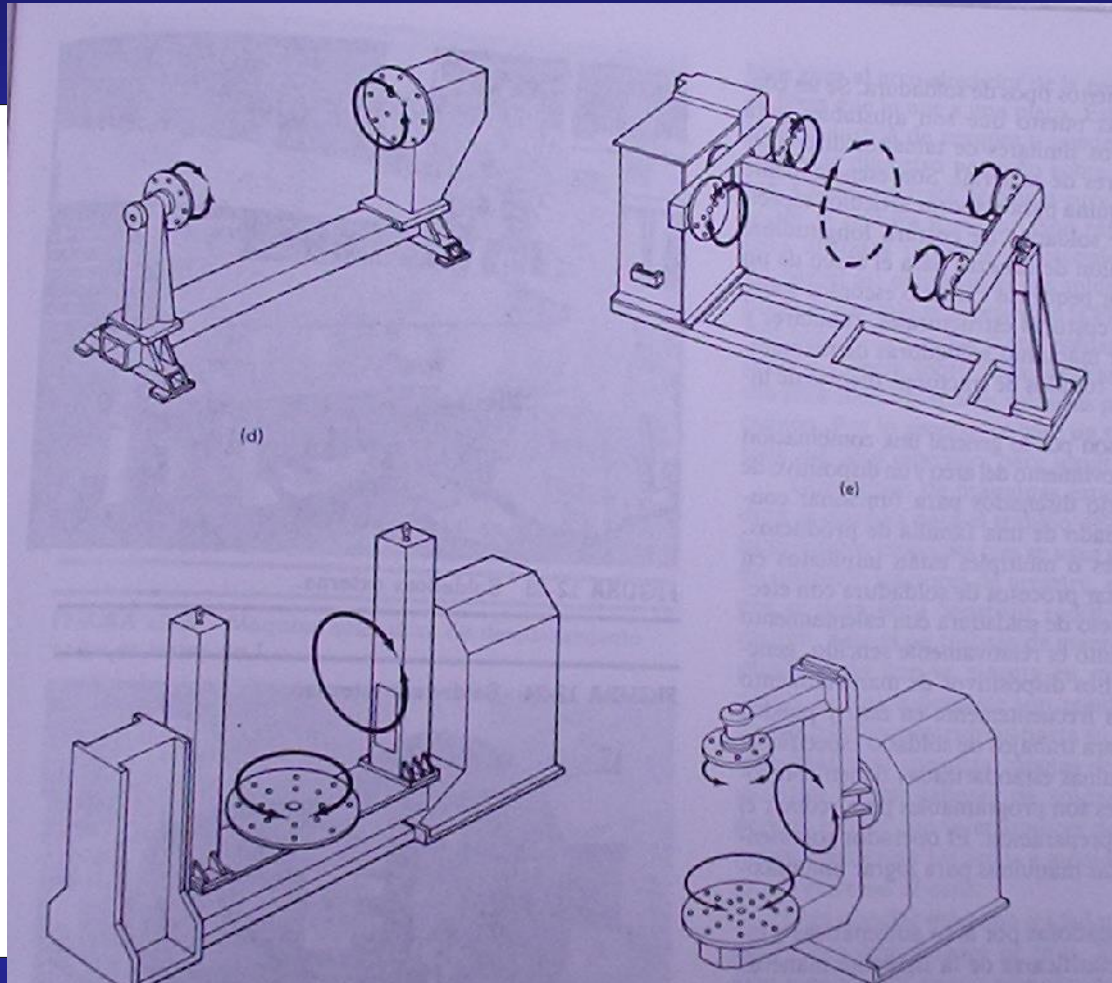

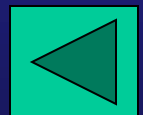
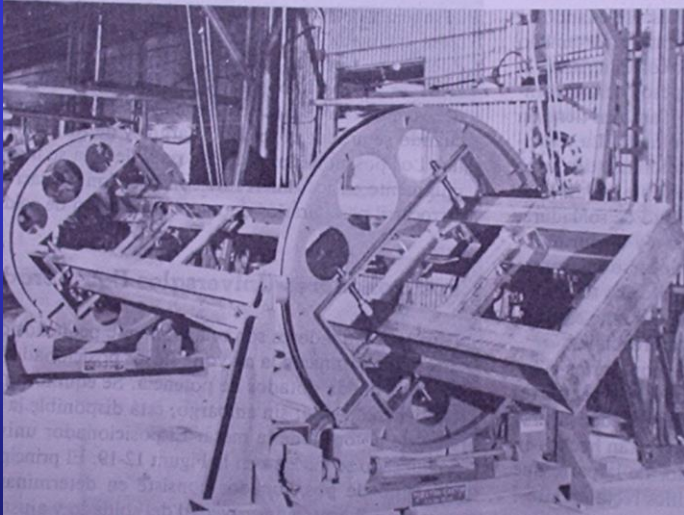
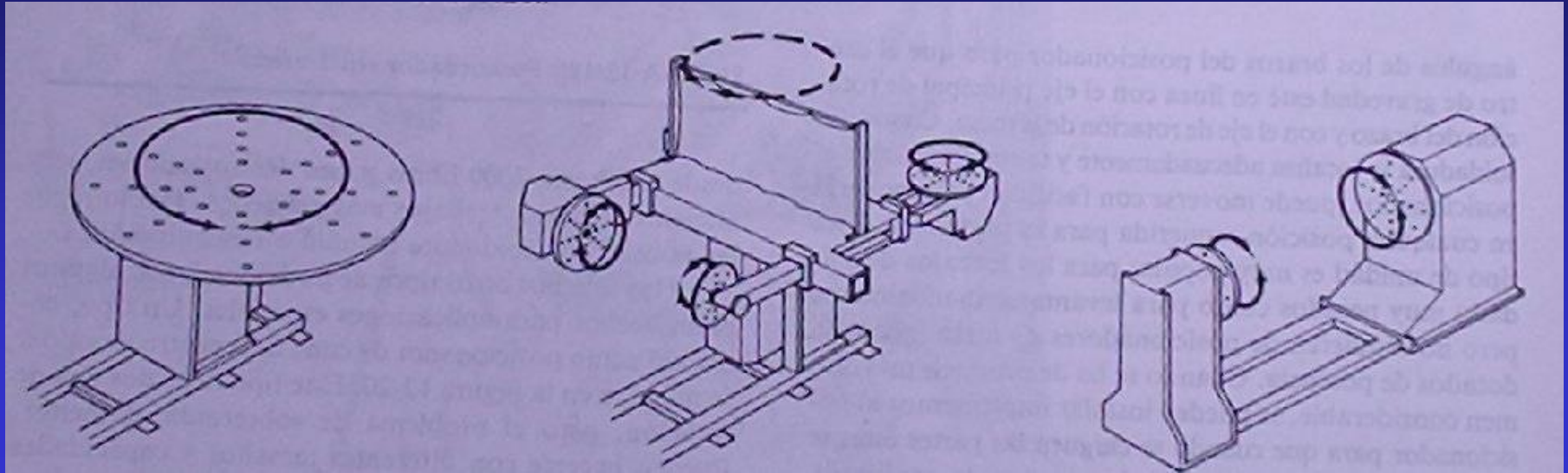

SOLDADURA ROBOTIZADA

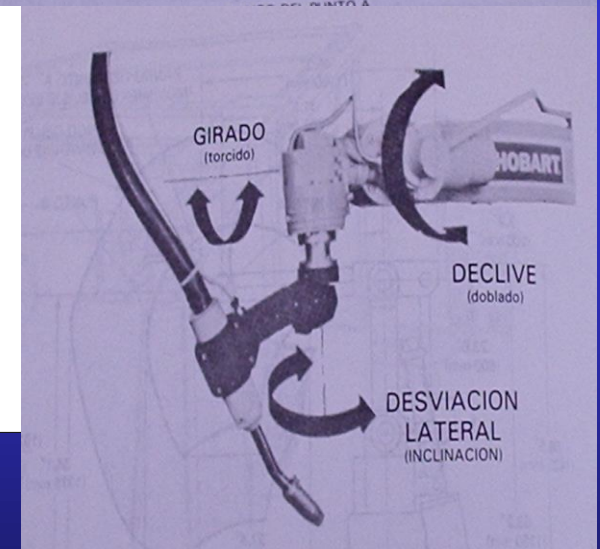
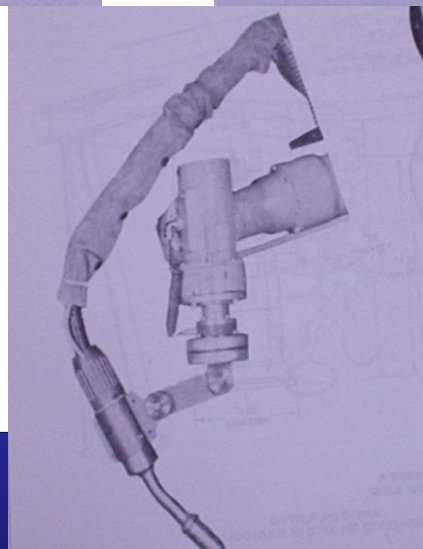
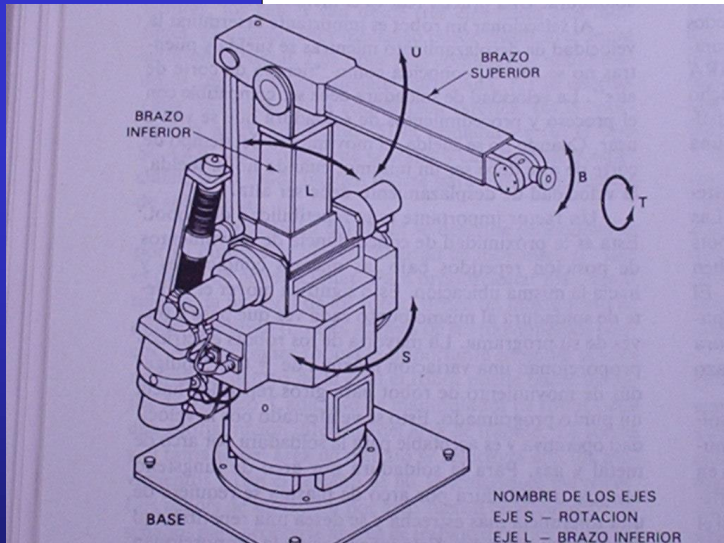
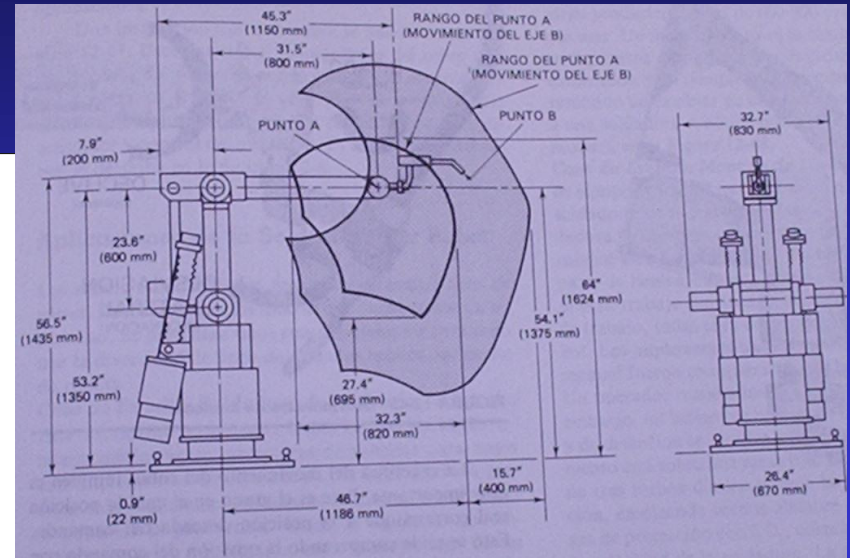
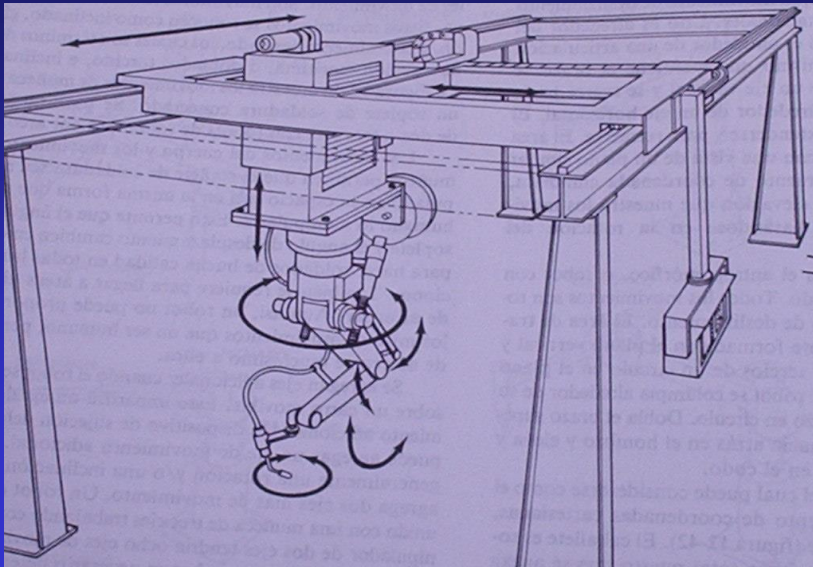



MUCHAS GRACIAS